

INSTITUTO BARRAQUER DE AMERICA

Vol. 7 - Nos. 1-2

1969

ARCHIVOS  
DE LA  
SOCIEDAD AMERICANA  
DE  
OFTALMOLOGIA Y OPTOMETRIA

10°. ANIVERSARIO

PARTE TERCERA

PRIMUM FORUM ●PHTHALMOLOGICUM

Lunes 16 a Viernes 20 de Marzo de 1970

Apartado Aéreo 20945, Bogotá (2) Colombia

**ARCHIVOS DE LA SOCIEDAD  
AMERICANA DE OFTALMOLOGIA  
Y OPTOMETRIA**

INSTITUTO BARRAQUER DE AMERICA

ARCHIVOS

DE LA

SOCIEDAD AMERICANA

DE

OFTALMOLOGIA Y OPTOMETRIA

---

---

Vol. 7

1969

Nos. 1-2

---

---

SECRETARIO GENERAL Y DE REDACCION:

**SALOMON REINOSO A., M. D.**

APARTADO NACIONAL 700/2

BOGOTA - COLOMBIA

S O C I E D A D   A M E R I C A N A  
D E  
O F T A L M O L O G I A   Y   O P T O M E T R I A

JUNTA DIRECTIVA

Salomón Reinoso A., M. D.

José I. Barraquer M., M. D.

Wesley Newton, O. D.

Francisco Barraquer C., M. D.

Carlos Téllez D., O. D.

Jaime Téllez D., M. D.

Hernando Henao R., O. D.

SECRETARIO GENERAL Y DE  
REDACCION

Salomón Reinoso A., M. D.

TESORERO

Carlos Téllez D., O. D.



SUMARIO - SUMMARY

	<i>Págs.</i>
ASSIS GEORGE, M. D. REVEIZ EDUARDO, M. D. METASTATIC TUMOR IMPLANTS IN THE ANTERIOR CHAMBER ... ..	9
BARRAQUER JOSÉ I., M. D. HENA O HERNANDO, O. D. EXPLORACION FUNCIONAL EN QUERATOPLASTIA REFRACTIVA. ...	13
BELLOWS JOHN G., M. D. AN EVALUATION OF CRYOEXTRACTION AFTER 700 OPERATIONS ...	25
DE VALENTIN G., M. D. CEFALEAS DE CAUSA OCULAR .....	31
DOS SANTOS AYRES MARILIA, M. D. ESTUDIO COMPARATIVO ENTRE APLANOTONOMETRIA DE GOLDMANN E MAKLAKOV EM 100 OLHOS NORMAIS .....	45
GUIDO PEDRO A., M. D. UN CASO DE PARALISIS NUCLEAR DEL III - PAR .....	63
HASSAN MULHIM A., M. D. A CLINICAL CORRELATION BETWEEN FOCAL INFECTION AND EYE DISEASES .....	69
KAPLAN MILTON M., O. D. KATZIN HERBERT M., M. D. CORNEAL CYLINDERS IN REFRACTIVE KERATOPLASTY .....	83
KAPLAN MILTON M., O. D. REFRACTIVE KERATOPLASTY - VERGENCY CALCULATIONS .....	102
KENNEDY JOHN R., O. D. A TECHNIQUE FOR DIAGNOSTIC CONTACT LENS FITTING .....	133

MALIK S. R., M. D. GUPTA A. K., M. D. SINGH GURBAX, M. D. NON-OCULAR MANIFESTATION OF SYMPATHETIC OPHTHALMIA ...	139
SOLARES Z. JAIME UN SINDROME D'ALPORT .....	143
WEIGELIN E., M. D. ZIESMER, M. D. THE MOSES EFFECT DURING IN VIVO IMPRESSION TONOMETRY ON THE RABBIT EYE .....	153
NECROLÓGICA MR. PETER VERE RYCROFT M. A.,	159
NOTICIAS - NEWS .....	161
SOCIEDAD AMERICANA DE OFTALMOLOGIA Y OPTOMETRIA: 1969 SCIENTIFIC ACTIVITIES .....	163
ACTIVIDADES CIENTIFICAS PARA 1969 .....	163

## METASTATIC TUMOR IMPLANTS IN THE ANTERIOR CHAMBER

BY

GEORGE ASSIS - MASRI M.D.

EDUARDO REVEIZ R. M.D.

Cali - Colombia.

### *Case report:*

V.B. 78 years old, white male, came to the office complaining of pain, photophobia, lacrimation, blurred vision, and congested left eye for the last three days. He had lost 20 pounds in two months and noticed low back pain.

Examination revealed visual acuity of 20/25 in the right eye and 20/40 in the left eye with correction. Refraction: OD = +1.25 ; OS = +0.75.

The right eye was normal with incipient nuclear senil cataract. The left eye was tender to palpation and showed market injection mainly circumcorneally. The pupillary reaction was impaired and the pupil was miotic and slightly distorted to the lateral side where a white, coliflower-like, mass occupied part of the angle of the anterior chamber, mostly the lateral upper quadrant. This mass was avascular, well circumscribed and adherent to the adjacent iris. The aqueous was turbid, three plus Tyndall, and there were small keratic precipitates on the posterior surface of the cornea, composed of lymphocytes. The iris itself was edematous with loss of normal luster. There was absence of posterior or anterior synechiae at gonioscopic examination. Ophthalmoscopic examination was not done at this time. The intraocular pressure was 12 mm Hg. in the right eye and 17 mm Hgm in the left eye. The diagnosis was acute anterior uveitis, secondary to local necrosis of metastatic tumor in the anterior chamber. Few days. after treatment with local 2.5% Hydrocortisone every 2 hours and Atropine 1%

Fig. 1. Photograph showing the tumor in the upper lateral quadrant.

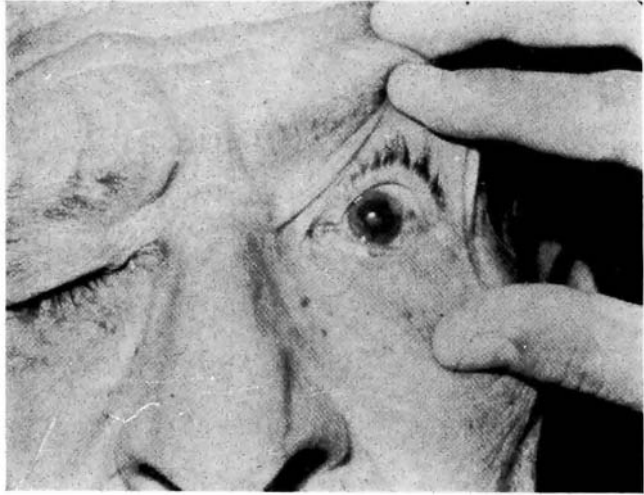

gtts twice a day, the uveitis subsided and the ophthalmoscopic examination with indirect ophthalmoscope was done. No tumor mass were seen up to the ora serrata. Transillumination was negative except at the side of the tumor mass. The vitreous showed moderate Tyndall of inflammatory cells and the optic disc and the posterior pole were normal. The visual acuity improved to 20/25 c.c. and the intraocular pressure dropped to 12 mm Hg.

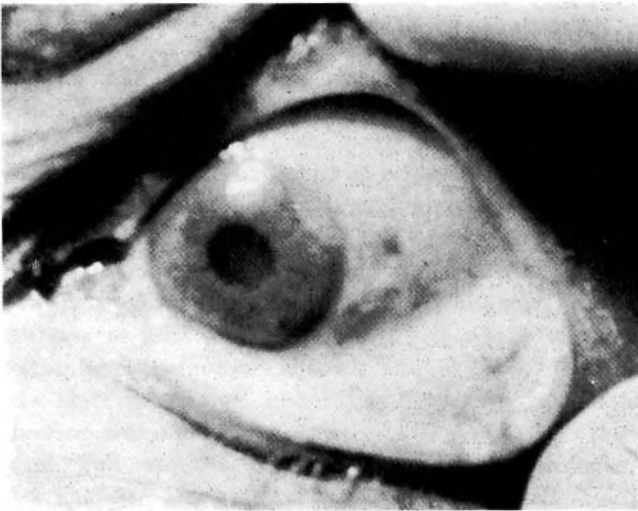

Fig. 2. Close view of the tumor mass.

#### METASTATIC TUMOR

General physical examination: The only positive findings were a nodule in the left lobe of the thyroid, hard, regular, non tender and mobile. There was a small, firm nodule in the left upper flank measuring  $1 \times 15$  cms. fixed to the skin. Rectal examination disclosed an enlarged but benign prostate to palpation.

Laboratory findings: The hemogram as well as the peripheral smear were normal. Bone marrow was also unremarkable. Chest films revealed a wide medias-

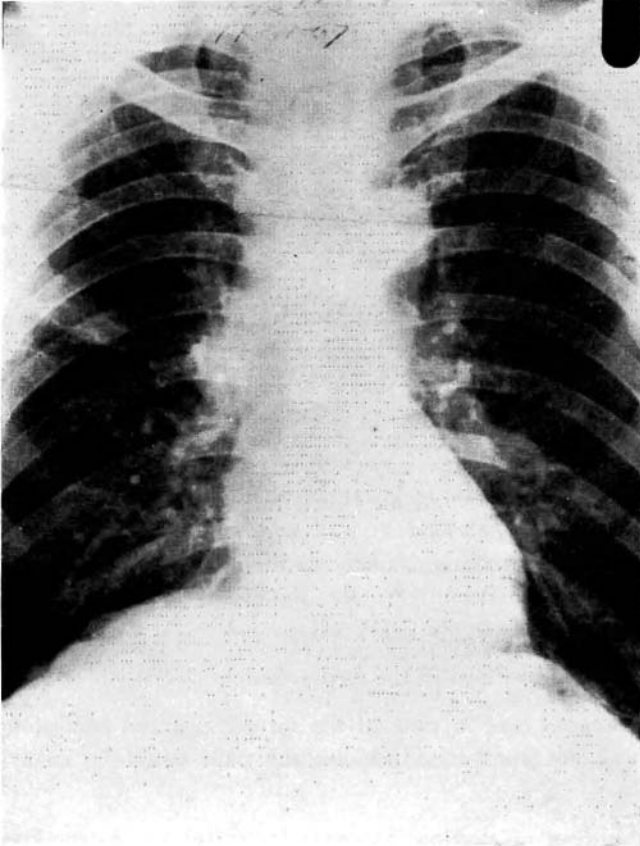
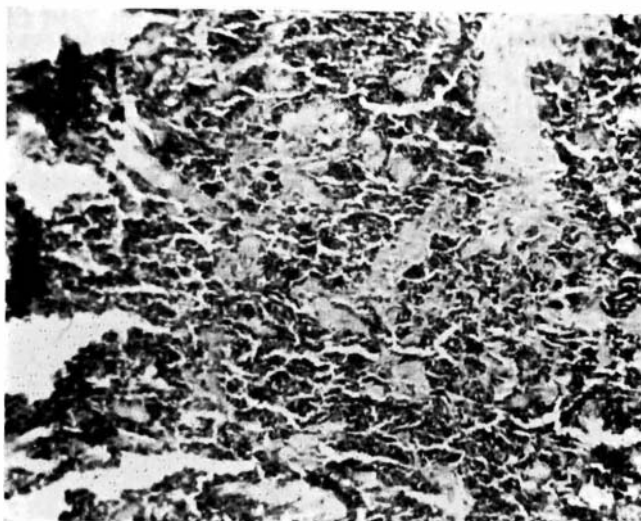

Fig. 3. X-ray of the chest. Wide mediastinum and prominent right hilum.

tinum with a nodule in the right hilum and a prominent aortic arch. Bronchoscopy and bronchograms were normal (there was no deformity of the main bronchi).

Biopsies were performed of the thyroid nodule and the abdominal wall nodule. Pathology reported nodular thyroid and in the abdominal wall nodule,

Fig. 4. Microscopic view of the abdominal nodule. Numerous atypic lymphocytes without any pattern of arrangement and a sarcomatous stroma.



many abnormal lymphocytes, with hyperchromatic nuclei, without arrangement and with a sarcomatous stroma. The diagnosis was lymphosarcoma, lymphocytic type. The patient was treated with Nitrogen Mustard, 0.2 mg  $\times$  Kg., divided in two dosis. The white blood count dropped to 3.000 but the drug was well tolerated.

Discussion: This is the case of a well demonstrated lymphocytic lymphosarcoma with metastasis to the left eye, abdominal wall and nodes. The probable mechanism of this anterior uvea metastasis is through the long ciliary arteries though typically they appear more frequently in the posterior choroid by way of the short posterior ciliary arteries.

The original tumor was probably located in the mediastinum.

We considered this an advanced case in view of the spread, age and condition of the patient. The eye was not enucleated because the pain could be easily controlled.

Nitrogen Mustard was the drug of election. In case of respiratory obstruction or hemoptysis, the mediastinum and the hilum of the right lung could be radiated.

Summary: This case showed that the eye is not infrequently the first site of malignant spread, and eye symptoms occasionally precede the diagnosis of the primary tumor.

*Univ. del Valle*

# EXPLORACION FUNCIONAL EN QUERATOPLASTIA REFRACTIVA

POR

JOSE I. BARRAQUER M., M. D.

HERNANDO HENAO R., O. D.

Bogotá, Colombia.

La corrección quirúrgica de una ametropía presupone el conocimiento previo, lo más exacto posible, de diversos parámetros, tanto fisiológicos como ópticos, que determinan las características del ojo, no solo para poder corregir adecuadamente su ametropía, sino para valorar en forma adecuada el grado de acción quirúrgica, y valorar las modificaciones post-operatorias.

La secuencia que a continuación exponemos sigue paso a paso los puntos y pruebas establecidas en el correspondiente formato de nuestras historias clínicas, hechas especialmente para este tipo de intervención.

Las pruebas a considerar son las siguientes:

1) *Refracción Subjetiva*: Esta es realizada en el Refractómetro de Green a 12 mm. del vértice corneal. Es conveniente hacerla bajo ciclopegia. Ejemplo: -3.00 Esf. (-2.00 x 180) V = 0.80.-

El esquema óptico del ejemplo citado anteriormente, se representa diagramáticamente, en la siguiente figura (1).

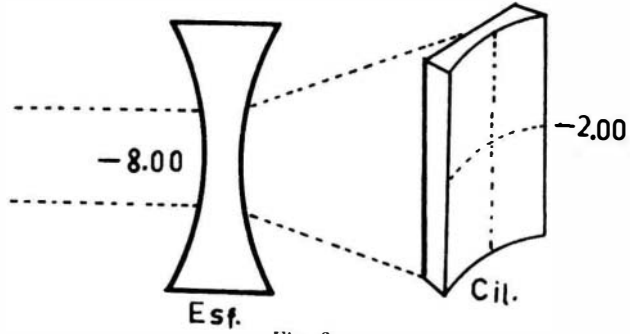

Fig. 3.

El efecto diagramático del uso de estas lentes sobre un ojo esquemático es el siguiente, el cual proporciona una emetropía inducida. (Fig. 4).

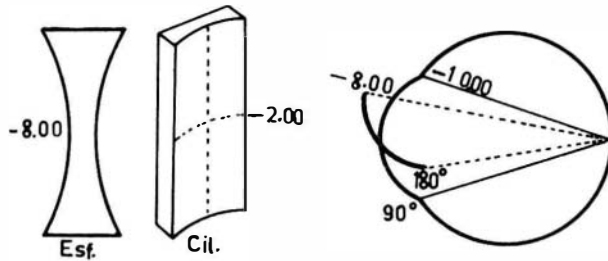

Fig. 4

2) *Equivalente Esférico*: El Equivalente esférico es en principio el valor básico a corregir en Queratomileusis (esférica) y está representado en el presente caso por una lente de -9.00 dioptrías, como podrá observarse en los siguientes diagramas (Figs. 5 y 6).

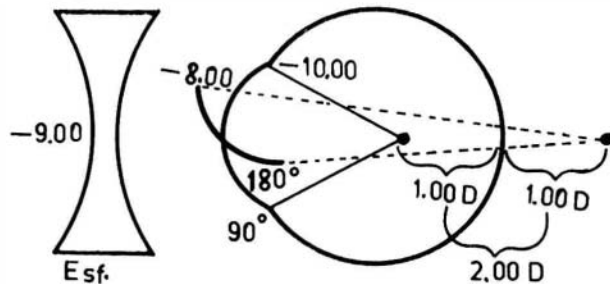

Fig. 5

*Círculo de mínima confusión:*

El efecto de la lente de -9.00 D sobre el plano vertical, lo hipocorrigió en 1.00 dioptría y en el horizontal lo hipocorrigió también en 1.00 dioptría. Esta situación da lugar a lo que se denomina el *Círculo de Mínima Confusión*.



Matemáticamente el equivalente esférico de una corrección cilíndrica, es igual a la combinación del poder de la esfera, más la mitad del valor cilíndrico. Así pues, usando el ejemplo anterior, tenemos que -8.00 (valor Esf.) combinado con -1.00 (mitad del valor cilíndrico, nos da un resultado de -9.00 dioptrías.

3) *Refracción en Vértice*: Es el poder efectivo de un lente corrector sobre el plano corneal. (Distancia entre la córnea y la lente oftálmica correctora).

Este concepto es básico en la adaptación óptica correcta de lentes convencionales de alta graduación en Lentes de Contacto, y en Queratomileusis.

La fórmula matemática de la refracción en vértice, se expresa de la siguiente manera:

$F_e$  = Nuevo poder dióptrico.

$F$  = Poder conocido.

$d$  = Distancia de córnea a vértice del lente, expresado en metros.

$$F_e = \frac{F}{1-d F}$$

En la actualidad existen varias tablas, las cuales simplifican y agilizan de manera práctica, el hallazgo del poder efectivo de una lente a determinada distancia.

Ejemplo: el poder efectivo en plano corneal de una lente de -9.00 d., es de -8.12 d.

4) *Refracción Objetiva Estática*: Esta información la determinamos por medio de dos instrumentos, a saber:

a) Retinoscopio de Hendidura.

b) Refractómetro de Rodenstock

Su valor tiene gran importancia, debido a la gran incidencia de ambliopías absolutas y relativas en casos con factores anisométricos altos, donde la conducción para elaborar un dato subjetivo adecuado es difícil y más si se trata de pacientes de corta edad. Es conveniente realizar estas pruebas bajo cicloplegia completa.

El dato de Retinoscopia Dinámica tiene algún valor en algunos de estos casos, especialmente si no se ha usado cicloplegia en la Retinoscopia Estática.

5) *Fijación*: Usamos de rutina la oftalmoscopia directa y empleamos dos instrumentos, a saber: Oftalmoscopio Oculus de filtro verde con círculo transparente en su centro (sistema de Bangerter) y el Visoscopio de Cuppers. Encontramos con mucha frecuencia, en casos de *alta miopía*, con fijación foveal, que no es posible obtener agudeza por encima de las 2/10 (20/100), después de su adecuada corrección óptica para lejos; sin embargo, para darnos una idea del posible grado relativo de ambliopía existente, tomamos agudeza sin visual de cerca, sin corrección óptica, obteniéndose magníficas agudezas, muchas veces por encima de las 8 decimas y (20/25) a distancias muy cortas entre el Optotipo y el ojo. Este fenómeno tiene su explicación, creemos en la magnificación inducida, pero en nuestra historia es importante anotar la relación entre la agudeza de lejos con corrección y la de cerca sin corrección.

Hemos podido observar que ojos míopes ambliopes con mala agudeza de lejos (una vez corregido ópticamente), pero con buena agudeza sin corrección de cerca tienen buen pronóstico de recuperación post-operatorio espontáneo o por medio de la Pleóptica después del tratamiento Quirúrgico.

La clasificación de las fijaciones que usamos es la siguiente:

- a) Foveal estable o inestable.
- b) Para-foveal estable o inestable.
- c) Macular estable o inestable.
- d) Para-macular estable o inestable.
- e) Excéntrica estable o inestable.
- f) Ausencia de fijación.

6) *Queratometría u Oftalmometría de Cara Anterior*: Conviene emplear instrumentos que efectúen la medición sobre la menor área corneal posible, con el fin de obtener valores de vértice.

En nuestra práctica utilizamos dos instrumentos de diferente fabricación:

El Oftalmómetro Micrométrico C. I., producido por la American Optical Co., calibrado para un índice de refracción de 1.3375.

El Oftalmómetro Zeiss, calibrado para un índice de refracción de 1.332, con cuerda de 4.00 mm., para radios grandes y 2.5 mm., para los pequeños.

El Cornealómetro Obrig, (esquemas en figuras N<sup>o</sup> 6 y 7) que permite el estudio topográfico, construido para nosotros con escala, índice 1.376 que empleamos para los cálculos de la talla corneal. Este instrumento efectúa la medición en un área corneal de un diámetro aproximado de la décima parte del radio

objeto de medición. O sea 0.6 mil para 6.00 mm., de radio y 1.1 mm. de diámetro para 11.00 mm. de radio.

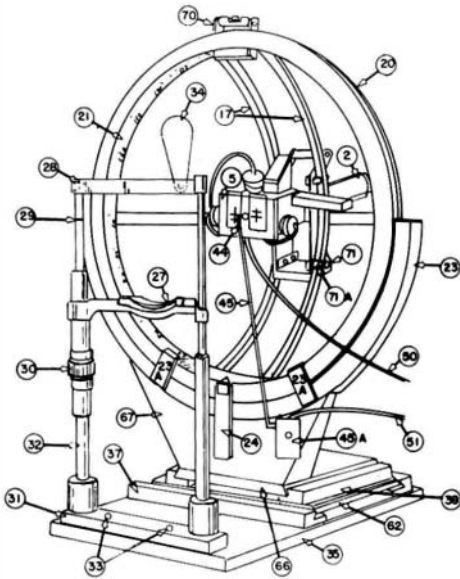

Fig. 6

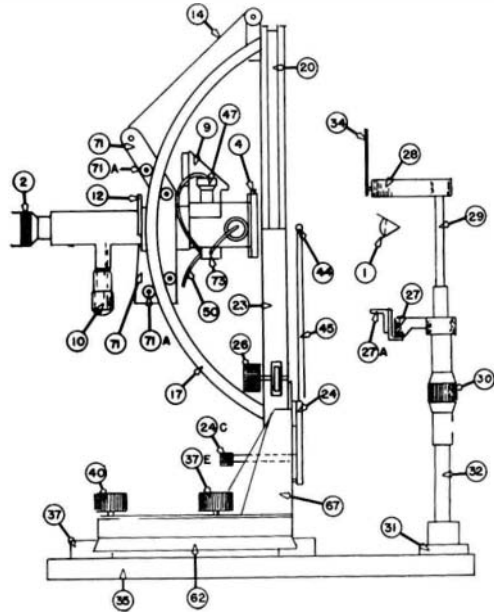

Fig. 7

Cuando la exploración Oftalmométrica se hace con instrumento de índice 1.3375 o 1.332, debe emplearse una tabla de equivalencias dióptricas con radios de curvatura en mms., según el índice empleado por el constructor del instrumento.

Siguiendo el ejemplo propuesto en este trabajo, vamos a asumir que la lectura oftalmométrica es: (43:00) (45:00) — 2.00 x 180; estos valores tienen la siguiente presentación diagramática (Fig. 8).

7) *Promedio Queratométrico u Oftalmométrico*: Siguiendo el diagrama anterior (Fig. 8), podemos ver que el punto dióptrico medio, (promedio Oftalmométrico), se encuentra sobre los 35 grados y 145 grados, con un valor dióptrico de: 44:00 D., o sea el valor promedio de la córnea supuesta con una lectura de (43:00) (45:00) -2.00 cil x 180.

8) *Oftalmometría Cura Posterior*: Se debe determinar el valor refractivo total de la córnea, (lado objeto o lado imagen) para conocer así, si una modificación

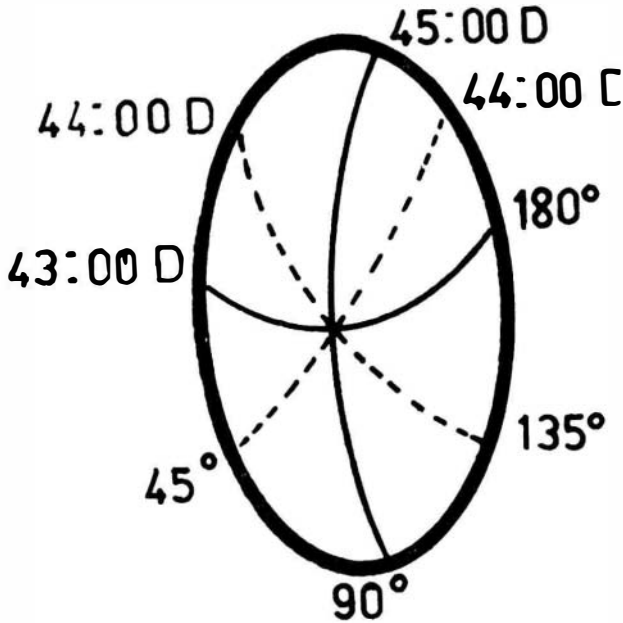

Fig. 8

postoperatoria se debe a la regeneración del espesor corneal (zona óptica pequeña, a Ectasia o zona óptica grande o resección profunda) o a otros factores extra-corneales.

La medición del radio de la superficie posterior de la córnea, la hacemos con el oftalmómetro Zeiss; sus colimadores de proyección muy luminosos, permiten hacer la lectura sobre las imágenes de la cara posterior, más pequeñas y tenues que las de la cara anterior. (El fondo negro que proporciona la pupila en midriasis facilita grandemente la lectura).

El dato suministrado por el oftalmómetro no corresponde a la realidad si bien este es el que se anota en la hoja de exploración. El valor verdadero de radio se obtiene aplicando una fórmula bastante compleja y que será objeto de otra publicación.

9) **Diámetro de la Córnea:** Para determinarlo utilizamos el pupilómetro de la Casa Zeiss ó el de Titmus, el cual consiste en un tubo con una escala

reticulada, la cual se sobrepone en el plano corneal y por simple alineamiento de las rayas del retículo: Sobre los dos extremos del limbo, se lee en milímetros el diámetro corneal. También en una Lámpara de Hendidura Zeiss, se ha acoplado un ocular con una escala graduada en mms., que al emplear el aumento 10 X, permite la lectura directa del diámetro máximo y mínimo.

En todos los casos se emplean mediciones tanto verticales como horizontales, anotando que el diámetro vertical tiene un promedio de 0.5 mm., menor que el horizontal. Esto es debido a que la gran mayoría de los ojos poseen un discreto astigmatismo con la regla, considerado como fisiológico.

Generalizando, podemos decir que el mayor diámetro corneal, corresponde al meridiano menos curvo de la córnea. Este hecho es particularmente evidente en los altos astigmatismo oblicuos (Ref. Tabla).

10) *Espesor Corneal*: Es tomado en vértice, con el aparato de Jaeger fabricado por Haag Streit. Permite conocer el espesor de la resección que deberá emplearse y hacer comprobaciones post-operatorias sobre el grado de acción quirúrgica y regeneración corneal.

11) *Transparencia de la Córnea*: Esta inspección se hace bajo la lámpara de hendidura, y también usamos fluoresceína a fin de observar más cuidadosamente la posible presencia de algún proceso de tipo activo o evolutivo, también pueden observarse tenues leucomas, así como su densidad y relación con el área pupilar. Alteraciones de mayor intensidad son una contraindicación para la cirugía refractiva.

12) *Sensibilidad de la Córnea*: Utilizamos el Estesiómetro de Cochet Bonnet, siguiendo las instrucciones de su uso, descritas por ellos mismos así como el del Prof. Franceschetti, el cual contiene una gama de 10 pelos distribuidos de 1 a 200 gr. por mm<sup>2</sup>. Cada sensor está protegido por un tubo metálico, de donde sale al mover el cursor. (Fig. 9).

La calibración de los pelos (sensores) es de 1; 2; 5; 10; 20; 30; 50; 100; 150; y 200; gr. por mm<sup>2</sup>. Consideramos que el valor normal de sensibilidad corneal apical (3-4 mms. de zona) varía entre 5 y 20 g. por mm<sup>2</sup>., al utilizar este aditamento.

El estesiómetro de Cochet-Bonnet está montado dentro de una varilla hueca metálica (vástago) con cremallera, que permite deslizar un hilo de plástico con gran facilidad utilizando una sola mano. Las medidas comienzan desde la salida del hilo cubriendo una longitud que va de 5 a 60 mms. En el vástago está incorporada una escala, la cual es de fácil lectura, para controlar la extensión del hilo, gracias al sistema de cremallera de que está dotado. (Fig. 10).

QUERATOPLASTIA REFRACTIVA

Las cifras equivalentes entre la extensión del hilo y el peso en mg., son las siguientes:

<i>Longitud en mm.</i>	<i>Peso en mg.</i>
60 .....	11
55 .....	12
50 .....	13
45 .....	16
40 .....	20
35 .....	27
30 .....	35
25 .....	53
20 .....	75
15 .....	100
10 .....	140
5 .....	200

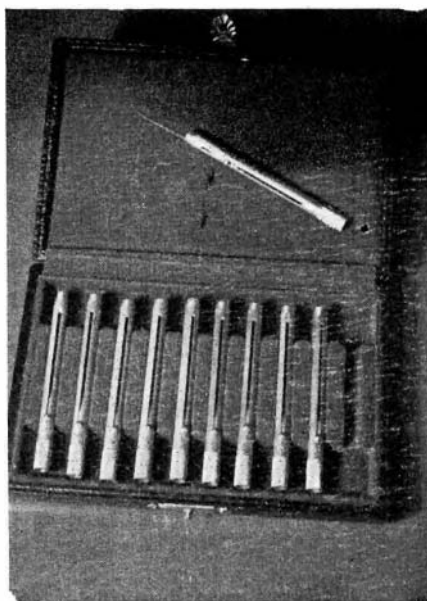

Fig. 9

Para proceder a la prueba, debe advertirse al paciente que ésta es absolutamente indolora. Al hacer el contacto del hilo de nylon con la córnea, esta debe hacerse en forma perpendicular, hasta observar la flexión del mismo, y controlar si el contacto es reportado por el paciente. Creemos que siempre se debe proceder utilizando la extensión máxima (60) y disminuyendo la longitud del mismo, hasta que la sensación sea reportada por el paciente.

La zona corneal utilizada por nosotros es la apical, dentro de un área de 3 a 4 mm., de superficie, ya que las zonas ópticas (corte) en Queratomileusis oscilan entre 5,5 y 6,5 mms.

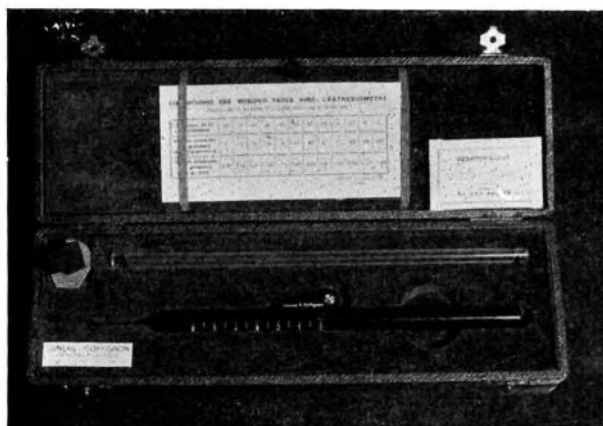

Fig. 10

Este estudio Estesiométrico preoperatorio, aparte de establecer la normalidad sensitiva de la córnea a intervenir, permite seguir en el post-operatorio, el proceso de reinervación de la córnea intervenida.

13) *Profundidad de la Cámara Anterior*: Tomada con el aparato de Jaeger, fabricado por Haag Streit, permite conocer asociado a la Ecoscopia Ultrasonica la longitud total del globo (Método de Gernet) y determinar si hubo modificaciones post-operatorias.

14) *Longitud Anteroposterior del Globo Ocular*: Para determinarla utilizamos el método de Gernet, Optico Ultrasonico, y nos permite establecer la refracción del ojo cuando existe catarata; el volumen del globo ocular para predeterminar el incremento de tensión con los anillos neumáticos y finalmente conocer si ha habido progresión post-operatoria en una miopía axial. Empleamos el Eco-Oftalógrafo de Siemens. (Fig. 11).

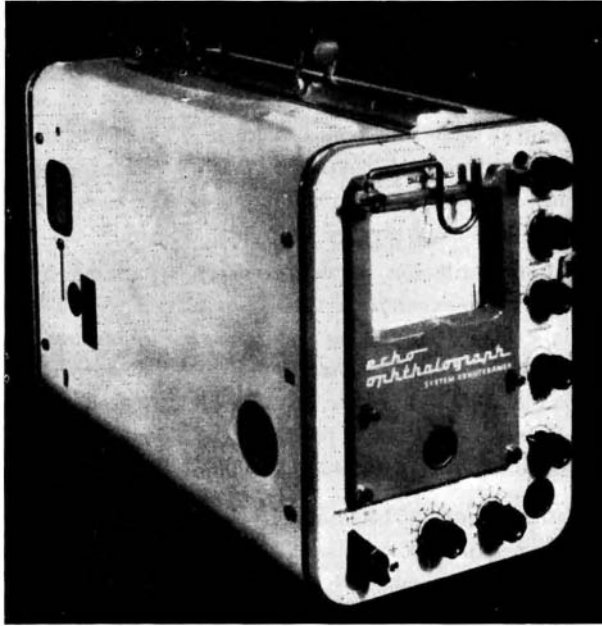
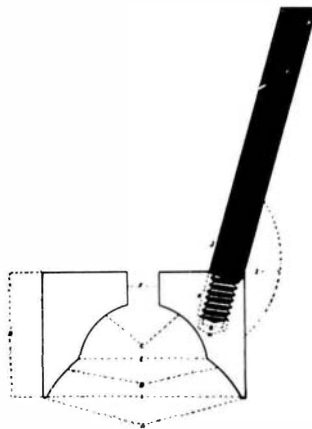

Fig. 11

15) *Determinación del Radio Escleral:* La utilidad de la determinación del radio escleral, en la exploración funcional en Queratomileusis, es conocer de antemano el radio apropiado del anillo de fijación neumática que deberá aplicarse sobre la esclera (B.).



**ESCLEROMETRO**

- A. Diámetro lente 10 mm.
- B. Espesor lente 11.5 mm.
- C. Radio central 6.60 mm.
- D. Radio periferia 12 - 12.5. 13.- 13.5 - 14.
- E. Diámetro Radio Central 12 mm.
- F. Perforación Centro 3 mm.
- G. Perforación para rosca con broca 2.30 mm.
- H. Rosca con macho 2.6 mm.
- I. Angulo perforación 70 grados.
- J. Longitud total del mango 60 mm.
- K. Longitud Rosca del mango 4 mm.
- L. Diámetro Radio Periferia 17 mm.

Fig. 12



El instrumento usado se denomina Esclerómetro (plano del instrumento Fig. 12) y consiste en una serie de 5 unidades hechas de material plástico transparente. Tiene un centímetro de altura, su cara anterior es plana con el fin de permitir la observación, su cara posterior es cóncava, con un radio predeterminado, en su parte central tiene una concavidad de 13 mm. de diámetro, a fin de liberar la córnea y los radios de la zona periférica y están calibrados a 12; 12.5, 13; 13.5 y 14 mms. radios que corresponden a los esclerales más frecuentes.

Previa anestesia por instilación, el esclerómetro se adapta al segmento anterior del globo ocular, y observando a través de él con ayuda del Microscopio, puede observarse la compresión de los capilares conjuntivales y determinar en ésta forma el radio de curvatura. También en muchos casos, la instilación de Fluoresceína Sódica, ayuda a observar diagramas fluoroscópicos, los cuales también proporcionan un medio adecuado para determinar el radio escleral, así como la presencia de astigmatismos esclerales.

16) *Tensión Intra-Ocular*: Usamos el Tonómetro Electrónico de Makay-Marg, el cual en forma rápida y precisa nos da la información. Con este instrumento se calcula que la cifra normal es de 16 a 20 mms. Hg., sin anestesia y de 18 a 22 mms., con anestesia local por Novocin.

17) *Fondo Ocular*: En este renglón se anota solamente cualquier modificación observada preoperatoriamente, para su comprobación ulterior.

Del estudio de todos estos datos y de la refracción del ojo congénere, se calcula la magnitud de la corrección (Corrección necesaria, a que debe ser sometido el ojo amétrope).

La valoración de estos datos, el cálculo de la corrección y evaluación de los resultados post-operatorios, serán objeto de futuras publicaciones

Apartado Aéreo 11357.

#### BIBLIOGRAFIA

- José I. Barraquer (1949) Queratoplastia Refractiva, Estudios e Informaciones Oftalmológicas (Instituto Barraquer) 2, 8.
- José I. Barraquer (1958) Método para la talla de injertos Laminares en estado de Congelación Profunda, Nueva Orientación para la Cirugía Refractiva. Arch. Soc. Amer. Oftal. Optom. 1, 232.
- José I. Barraquer (1964) Queratomileusis para la corrección de la Miopía Arch. Soc. Amer. Oftal. Optom. 5, 27.
- José I. Barraquer (1967) Keratomileusis. Int. Surgery 48, 103.
- Hernando Henao R. Comunicaciones personales. 1964 - 1967.

## AN EVALUATION OF CRYOEXTRACTION AFTER 700 OPERATIONS

BY

JOHN G. BELLOWS, M.D., Ph. D.

Chicago, U.S.A.

Six years of experience with cryoextraction in over 700 operations convinces me that cryoextraction is the operation of choice for the removal of cataracts in adults. A comparison of my results obtained using the cryoextractor with those obtained prior to 1961 using the forceps and erisophake demonstrates conclusively that cryoextraction is simpler, safer and superior to the time-honored methods.

The superiority of the cryoextractor over the erisophake or forceps is in its mechanical advantage in grasping and holding the cataract. The greater strength of the hold upon the cataract with the cyroprobe is readily made obvious when the breaking point of an ice-column is compared with the breaking point of the lens capsule <sup>1</sup>. The breaking point of the intralenticular ice mass at a temperature of -30° C., produced by the cryoextractor is more than 1,000 grams, while the breaking point of the capsule held by the erisophake or forceps is 7.5 grams... a ratio of 130 to 1. With this powerful hold upon the cataract obtainable with the cryoextractor the surgeon can safely apply more traction to remove a cataract than has been heretofore possible. The cyrosurgeon who feels relatively secure against capsular rupture has substituted traction for counter-pressure and has thereby radically modified and simplified the operation for the removal of cataracts.

### *Absolute indications for Cryoextraction*

The ophthalmologist who does not choose to discard time-honored methods for all cataracts must certainly consider cryoextraction in those instances when it is unquestionably the superior method as in removing an intumescent cataract.

Three other conditions in which cataract cryoextraction is superior to the older methods are: (1) when the vitreous covers a subluxated lens; (2) when vitreous presents itself immediately after the cornea has been sectioned; and (3), when a cataract is to be extracted from a highly myopic eye with liquified vitreous. Because of the interposing vitreous in the first two conditions, it is difficult to grasp the cataract with forceps or the erisophake, but with the cryoextractor the surgeon simply brushes the vitreous aside enabling application of its tip to the cataract to produce fusion and then the cataract is lifted out. In the third instance, cryoextraction without counterpressure minimizes the possibility of vitreous loss.

### *Principles and Technique of Cryoextraction*

To qualify for performing cryoextractions, the ophthalmologist must meet three basic requirements. First he must familiarize himself with the cryoextractor of his choice. Second he must develop sufficient skill by using it on experimental animals or cadaver eyes. And lastly, he must observe cryoextractions performed by an experienced cryosurgeon. Further, it is highly desirable that initial cryoextractions be performed with a wide iridectomy to minimize the possibility of iris freezing.

The technic of cryoextraction uses the same preliminary procedures as those employed in the conventional methods. When a complete iridectomy has been performed, the surgeon merely lifts up the cornea with one hand and with his other hand applies the tip of his cryoprobe to the superior portion of the cataract (Fig. 1). In the round-pupil extraction an assistant raises the cornea while the surgeon retracts the iris out of harms way and to expose the superior portion of the cataract and uses his free hand to apply the tip of the instrument.

At this stage of the operation the two most serious complications peculiar to cryoextraction may occur, namely freezing of the cornea and the iris. \*

As soon as fusion occurs between the cataract and the tip of the cryoprobe, (and this can be verified both tactilly and visually) the surgeon raises the superior portion of the cataract above the rim of the iris thus breaking the corresponding zonular attachments. When resistance is no longer encountered the surgeon proceeds to slide the cataract out of the eye. Moderate zonular resistance requires lateral and medial rotation of the cataract. Extreme resistance necessitates additional rotations in the clockwise and counter-clockwise directions. If all of these maneuvers should fail, then the surgeon resorts to mechanical or enzymatic zonulolysis.

\* *vide infra.*

## CRYOEXTRACTION

If enzymatic zonulolysis is used at this stage of the operation, the surgeon thaws the tip of the instrument and separates it from the cataract. After using alpha chymotrypsin in the usual manner; he cools the instrument to the proper temperature; reapplies it to the cataract and then proceeds to extract the cataract.

After the cataract has been removed by cryoextraction the final steps of the operation are the same as used in the older methods.

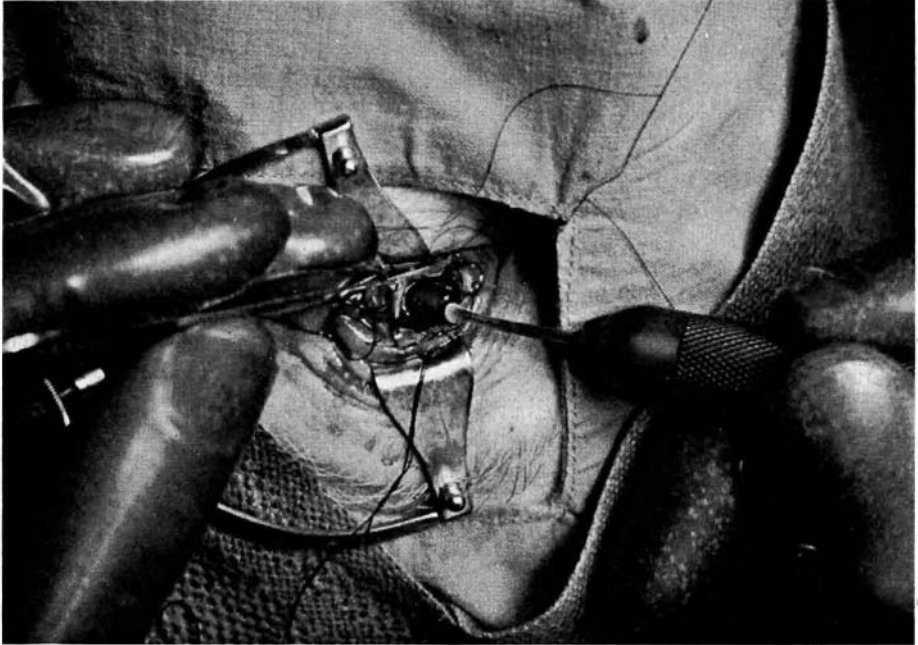

Fig. 1

The cornea is raised with forceps in one hand and the Bellows' cryoextractor is applied to cataract with the second hand.

### *Complications*

The complications that are mainly feared by cryosurgeons and which some ophthalmologists inexperienced with cryoextraction state as their reasons for opposing this new method are freezing of the cornea, iris, conjunctiva and sutures. In my series of 700 cryoextractions there were 6 cases in which a part of the iris was frozen, 1 case in which a small area of the cornea became involved, 8 instances in which sutures became adherent to the emerging probe or cataract

and not a single instance of conjunctival involvement. These complications by themselves had no perceptible influence on the successful outcome of the operations. In my opinion, the fear of freezing damage as a result of cryoextraction is greatly exaggerated. Instead, the ophthalmologist who has properly prepared himself to perform cryosurgery will find not only the risks and dangers of freezing trauma to ocular tissues are insignificant, but also will find the rewards are great.

### *Iris Freezing*

The complications most feared by ophthalmologists is iris freezing. Adherence of the iris to the cryoextractor usually occurs when the surgeon in applying the tip to the cataract accidentally includes a portion of the iris. The most frequent location for this mishap is that part of the iris concealed from view by the shaft of the instrument; this mishap occurs most often when round pupil extraction is performed with inadequate retraction of the iris. To avoid this complication, the surgeon must make certain that the iris is properly retracted and that the tip of the instrument does not touch the iris. Iris adherence and freezing can also occur if there is a delay in the withdrawal of the cataract fused to the cryoextractor. Under such circumstances the ice mass formed in the lens extends to reach the undersurface of the iris. This complication can be avoided by lifting the superior portion of the lens above the rim of the iris immediately after the cataract has become adherent to the cold tip.

If iris freezing does occur it usually manifests itself when the surgeon attempts to extract the lens. At this point, the adherent iris bulges out along with the cataract. The surgeon discontinues traction immediately to avoid iridodialysis. He separates the instrument and the adherent iris by thawing with a stream of saline or by activating the defrosting mechanism in those instruments supplied with such a unit. After thawing, the surgeon excises the frozen portion of the iris (especially if the contact has been a lengthy one), converting a peripheral iridectomy into a complete iridectomy. If the contact has been brief, excision of the involved iris is not necessary, because the minimal iridal reaction does not in itself, influence the outcome of the operation. This mishap should not deter the surgeon from once again applying the cold tip of the cryoprobe to the cataract and continuing with the cryoextraction.

### *Freezing of the Cornea*

Corneal complications occurring with cryoextraction are frequently mentioned by opponents of this method. In reality cryoextraction actually reduces the number of corneal complications. By eliminating the tucking of the cornea, an essential

procedure in the tumbling operation, striate keratitis and other evidence of endothelial trauma are rare complications of cryoextraction.

In over 700 cryoextractions only a small section of one cornea was frozen. In this freak accident the assistant released the cornea too soon and because the cryoextractor was an early model and was poorly insulated, a 1½mm area of the posterior surface of the cornea became adherent to it. The cornea was immediately thawed by a stream of saline. During the post-operative course cracks and folds were observed in the frozen area of the cornea. It eventually healed with no scarring and with 20/20 visual acuity. Freezing the cornea during cryoextraction can only occur either by a gross error of applying the tip of the cryoprobe to the undersurface of the cornea or by releasing the cornea before the cryoprobe with the adherent cataract passes through the corneoscleral opening. Even if the latter event should occur, it is doubtful that the cornea would freeze to the newer and better insulated instruments.

#### *Freezing of the Conjunctiva and Sutures*

Accidental freezing of the limbal based conjunctival flap or sutures is a minor complication. Such freezing usually occurs at the time when the instrument with the cataract fused to it emerges from the corneoscleral opening. If the conjunctiva or sutures should become adherent to the cryoprobe before the cataract is completely emerged, then traction must be halted and the undesirable fusion thawed. If the sutures become adherent after the cataract has been completely extracted, the adherent sutures are separated simply by freezing them by thawing before tying.

Critics of cryoextraction who mention the danger of freezing damage to the deeper structures of the eye, i. e. vitreous, choroid or retina are apparently unaware of the reported gradient temperature studies. These studies verify that it is impossible with modern cryoextractors to freeze beyond 1 to 2 mm into the lens substance and therefore, freezing damage to the deeper structure of the eye simply does not occur when cryoextraction is properly performed (<sup>2</sup> and <sup>3</sup>).

Retinal detachment has also been cited as occurring more frequently following cryoextraction. However, statistics prove that retinal detachment occurs in 0.25% of the patients following cryoextractions and in 2.5% after conventional extractions <sup>4</sup>. In my series there were six retinal detachments, or less than 0.9%.

Because of the reduced incidence of capsular rupture and retained lenticular material when using cryoextraction, postoperative infections are rare, (1 in 700). Secondary membrane formation requiring discission as well as phakogenic uveitis glaucoma and hypersensitization are complications that have been almost completely eliminated.

*COMMENT*

As the ophthalmologist a generation ago was reluctant to accept the intracapsular method of extraction, so today the ophthalmologist is wary of the cryo extraction method. In both instances, this can be explained by the understandable antipathy to give up the old and familiar for the new and the unknown. Alexander Pope's advice applies in surgery as in language and fashion, "the same rule will hold; alike fantastic, if too new or old. Be not the first by whom the new are tried, nor yet the last to lay the old aside" <sup>5</sup>.

Cryoextraction is no longer confined to the laboratory but is an important addition to the armamentarium of the clinical ophthalmic surgeon. Critics concede that it is of special value in removing cataract in difficult cases; this suggests that it is indeed a simpler and safer procedure in treating all adult cataracts. Certainly those ophthalmologists who too frequently rupture the lens capsule would benefit by the reduced incidence of capsular breakage and its sequelae when using the cryoextractor. They will be well rewarded and delighted to find that cryoextraction makes fewer demands upon their physical and mental resources and that this new method gives them a greater certainty of a successful outcome. Finally, the superiority of cryoextraction is attested by the fact that no ophthalmologist, to my knowledge, once he had become proficient in cryoextraction has discontinued its use to resume the older methods.

30 North Michigan Avenue  
Chicago, Illinois 60602.

REFERENCES

1. BELLOWS, J. *Cryotherapy of Ocular Diseases*. Published by J. B. Lippincott Co., Philadelphia, 1966.
2. SCHWARTZ, B. and FELLER, M.R.: Temperature gradients in the rabbit's eye. *Inv. Opth.* 4: 513-521, 1962.
3. KELMAN, C.: Cryoextraction, Correspondence. *Arch. Opth.* 74: 145-146, 1965.
4. KRWAWICZ, T. Personal communications, 1965.
5. POPE, A.: *Essay on Criticism*, 1711.

## CEFALEAS DE CAUSA OCULAR

POR

IGNACIO DE VALENTIN-GAMAZO, M.D.

Madrid - España

### *Introducción y etiología.*

Teniendo en cuenta que anatómicamente la órbita, el ojo y sus anexos, así como sus contexturas anatómicas, están situados en la cabeza y se relacionan y forman parte (algunos de ellos) de los propios elementos craneales e incluso intra-craneales, se comprenderá fácilmente que las alteraciones orgánicas patológicas de los mismos, puedan llegar a producir cefaleas.

Por otra parte, la práctica clínica oftalmológica nos demuestra diariamente, que también desde el punto de vista funcional, muchas de las cefaleas de los pacientes pueden tener como causas:

- a) Un defecto o vicio de refracción, con anormalidad o excesos de la acomodación.
- b) Un trastorno motor (heteroforia) con alteración del equilibrio muscular, que desencadena una anormalidad de la visión binocular.
- c) Afecciones oculares que cursan también con cefaleas, y
- d) por último, alteraciones neuropsíquicas (jaquecas oftálmica y oftalmopléjica), o de otra índole (intoxicaciones endógenas o exógenas; trastornos del metabolismo; alteraciones del sistema nervioso; hepato-digestivas, circulatorias o renales, alérgicas y enfermedades de órganos y cavidades de la cara, yuxta o perioculares), que cursan o pueden cursar a veces, con cefaleas y participación ocular.

Ateniéndonos al título del presente trabajo, vamos a ocuparnos, pues, exclusivamente, de las cefaleas de etiología ocular y por tanto, de aquellas producidas por las causas descritas en los apartados a), b) y c) precedentes.



Estudiemos cada una un poco más detenidamente:

A. *Consideremos primero los vicios o defectos de la refracción:*

La acomodación se obtiene merced a la acción del músculo ciliar situado en el interior del globo ocular, fuertemente innervado por una rama del trigémino: el nervio oftálmico. A su vez este, da una rama —el nervio recurrente de Arnold—, que inerva al menos parcialmente la duramadre, por lo cual, lógicamente, las irritaciones de las terminaciones ciliares del nervio oftálmico consecutivas a los esfuerzos de acomodación en los defectos de refracción, afectan también al segundo, provocando cefaleas por irradiación.

Es importante hacer constar que, en todos los vicios de refracción (pero sobre todo en los astigmatismos) paradójicamente cuanto más pequeño es el defecto, mayores trastornos astenópicos producen, siendo estos también más intensos en niños y sobre todo en jóvenes, que en personas de más de 48 ó 50 años, y ello debido a que tales defectos resultan compensables o neutralizables fácilmente con un esfuerzo de acomodación que realiza el ojo del paciente, sin participación de su propia voluntad, es decir, de una forma casi automática, por el principio fisiológico de “que todo órgano que no es perfecto tiende a la perfección, realizando el esfuerzo correspondiente”. Tal esfuerzo proporciona pues una mejoría visual, una ventaja visual y en su virtud el sujeto lo realiza casi constantemente, desencadenando más tarde o más temprano los síntomas astenópicos. Por el contrario, los defectos grandes y los pequeños en personas de más de 50 años, producen menos trastornos porque, quizá en un principio quieran ser compensados con el esfuerzo de acomodación, pero al no obtenerse por él ventaja visual ninguna, o ser ésta muy pequeña, el paciente y sus ojos dejan de realizarlo, siendo consultado entonces el Oculista, no por las cefaleas, sino por la mala visión. Una cosa similar ocurre también con las pequeñas alteraciones musculares de la acomodación-convergencia, debidas no a defectos de refracción, sino a afecciones generales que disminuyen el estímulo nervioso o el tono muscular (como en la histeria, neurastenia, estados linfáticos, diabetes, lactancia, tuberculosis, miastenia, etc.). como más tarde veremos.

Los defectos o vicios de refracción productores de cefaleas, siguiendo el orden de mayor frecuencia o intensidad, según mi experiencia, son:

- 1º El “astigmatismo”
- 2º La hipermetropía.
- 3º La miopía.

1º *El “astigmatismo”.*

En el ojo astigmático no toda la superficie curva refringente de la córnea, por ejemplo, tiene el mismo radio de curvatura y por tanto, no posee el mismo valor

dióptrico en todos sus meridianos, sino que éstos varían de una forma gradual y progresiva desde uno de ellos, cuya refracción alcanza su máximo valor, hasta otro, perpendicular al primero, en que la refracción es mínima. Por tanto, al ser atravesadas cualquiera o varias de las superficies astigmáticas por un haz de rayos luminosos, jamás podrán estos coincidir en el mismo punto y entonces las imágenes aparecen difusas. Esta difusión se realiza en dirección del meridiano desenfocado, por lo que la visión resulta más nítida en el sentido del citado meridiano. Sin embargo, no llega a apreciarse el ligero alargamiento que las figuras debieran tener en dirección del meridiano desenfocado, porque la adaptación visual consigue una neutralización de las porciones más defectuosas de las imágenes, pero, por el contrario, aparece difuso todo el conjunto por no formarse imágenes limpias, nítidas, en la retina.

El ojo humano consigue pues obtener (dentro de ciertos límites y en los defectos de pequeña intensidad) una corrección o neutralización del defecto astigmático, merced a contracciones del músculo ciliar, que modifican la curvatura y por tanto el poder de refringencia del cristalino, y como sólo es preciso variar esta refringencia en un eje determinado (pues el perpendicular puede resultar normal, hipermetrópico o miópico), resulta que el tal músculo ciliar ha de contraerse de una forma anormal para conseguir que el meridiano de refracción mínima alcance el valor del de la máxima, ya que la acomodación negativa (es decir, la disminución de la refringencia del meridiano que tiene la máxima), es muy pequeña y no resulta apreciable y por tanto útil. Pero no es esto solo, sino que en los meridianos intermedios a los dos principales a que nos hemos referido, como cada uno tiene diferente refracción, la contracción del músculo ciliar ha de ir disminuyendo desde el eje del meridiano de mínima hasta el de máxima, para poder obtener la neutralización más perfecta del defecto. Por tanto, se puede comprobar ahora que esta acomodación tan específica y delicada ha de fatigar más que aquella otra que hace variar de manera uniforme el valor de la refracción en todas las direcciones del cristalino (hipermetropía o miopía). Finalmente, téngase en cuenta también, que pueden darse simultáneamente ambas acomodaciones, en los casos de defecto astigmático, combinado con otro esférico. Por todo ello podemos ahora explicarnos, por qué son los astigmatismos, y precisamente los pequeños (aquellos compensables con un esfuerzo de acomodación), los que según nuestras observaciones producen el mayor porcentaje de cefaleas oculares refractivas, de frecuente localización frontal y occipital, no siendo en muchos casos el síntoma único, sino que frecuentemente se acompañan de un cortejo sintomático multiforme, de apariencia neurológica en ocasiones, en cuyo diagnóstico diferencial puede ayudar decisivamente el Oftalmólogo. Como muestra de lo que decimos, puede servir la siguiente historia clínica, entresacada de las ya muy numerosas que tenemos en nuestro Departamento.

*L. P. M.* (mujer de 13 años de edad).

Bien constituida. Escolar, que rinde poco en sus estudios. Nunca ha usado gafas, es más, hace meses que ha visto un Oculista y dijo que no las necesitaba.

Me la envían a consulta el 12 de marzo de 1966, del Departamento de Electroencefalografía (Dr. Armayor), por padecer desde hace varios años cefaleas, escotomas centelleantes y síntomas de mareo, sin convulsiones ni pérdida de conciencia; sospechando solamente pudiera existir algún trastorno vestibular derecho.

Toda la exploración neurológica hasta ahora practicada, ha resultado negativa, así como la otológica. Los análisis también eran normales.

La exploración Oftalmo-Neurológica arroja, resumidamente, los siguientes datos: Globos oculares: discreta esotropía del ojo derecho por ligera paresia del músculo recto lateral. Polos anteriores oculares, medios transparentes y fondo de ojo, resultan sensiblemente normales. Campimetría y angio-oftalmo-dinamometría, también normales, así como la tonometría ocular.

Funcionalmente encuentro: agudeza visual sin corrección, de lejos: O.D. = 0.3 O.I. = 0.3 y de cerca: O.D. = 2 y O.I. = N° 1. A la visión binocular presenta ligera heteroforia. Practico graduación de vista, hallando en O.D. un astigmatismo de -1 d. a 35° y en O.I., otro de -0,50 d. a 180°, ganando de visión con la corrección óptica de lejos: O.D. = 0,8 y O.I. = 1; y de cerca a O. = N° 1. Sin embargo, como se ve, de lejos el O.D. no alcanza el 100% de visión, por una pequeña ambliopía ex anopsia. En visión binocular, con esta corrección desaparece por completo la heteroforia, consiguiendo pues, fusión perfecta de tercer grado (estereopsis) en ortoforia.

Se la prescribe como todo tratamiento el uso constante y permanente de la corrección óptica (gafas). En el mes de junio de 1966 me pongo en comunicación con la paciente, y me informa que todos sus trastornos han desaparecido desde que usa las gafas, y sus padres me dicen que ellos y los profesores han constatado un mayor rendimiento de la escolar en sus tareas. En diciembre de 1966 vuelvo a interesarme por la paciente, y me confirman nuevamente cuanto me dijeron en el mes de julio.

Al respecto de todo lo que anteriormente queda expuesto, nosotros publicamos un trabajo en 1955, en el que se aporta la hipótesis diencefálica en la etiopatogenia no sólo de las cefaleas, sino también de una serie de alteraciones funcionales que aparecen en muchos casos juntamente con aquellas, consecutivas todas a un defecto o vicio de refracción ocular y que sirven, precisamente, para diagnosticarlas diferencialmente, de aquellas otras que no tienen esta causa refractiva.

Se basa dicha hipótesis, en la consideración de las formaciones anatómicas que encontramos en el diencefalo relacionadas o conexas entre sí, así como en sus respectivas funciones. Tales son:

a) Tálamo óptico, con sus múltiples conexiones, por lo que debe ser considerado como importantísimo centro sensitivo como centro óptico intermediario (colocado entre la cintilla óptica y la vía óptica central), como centro olfatorio intermediario, como centro emocional y como centro vegetativo. En suma, es un centro sensitivo por excelencia y de "parada obligatoria", de todas las "vías sensitivas", del que arranca el último eslabón o tálamo-cortical de la vía sensitiva.

b) Cuerpo estriado, considerado como un centro de función esencialmente motora.

c) Región subtalámica, de la que nos interesa destacar aquí el núcleo de Luys, porque funcionalmente es un centro supraordinado de control para la musculatura lisa de los vasos, de los músculos de los ojos y de la vejiga. Dice Clara que "los fenómenos vegetativos tales como variaciones de diámetro pupilar, fenómenos vasomotores, y sudoraciones abundantes que acaecen en las grandes crisis dolorosas, se producirían porque los estímulos pasan del tálamo al núcleo de Luys".

d) Región infundibulo-tubérica, que encierra una serie de centros aún poco conocidos, pero de importancia vital para el organismo, por la función que desempeña, ya que sus núcleos representan los centros vegetativos más elevados de los conocidos hasta la fecha. Fisiopatológicamente es importante esta región, porque en ella están localizados los centros del metabolismo (hidratos de carbono, agua, etc.) del sueño, de la vigilia, los termo-reguladores, etc. Además de esto se ha comprobado que la acción de la psiquis en los procesos vegetativos se efectúa por intermedio del hipotálamo. Como todos estos núcleos se unen recíprocamente, se puede admitir que toda la región infundíbulo-tuberiana es de naturaleza simpática.

e) Situados también en el diencefalo o conexas con él, se hallan:

La vesícula hipofisaria, suspendida del tallo pituitario y la glándula pineal o vesícula Epifisaria.

f) Finalmente, recordemos que el aparato sensorial de transmisión del ojo, se compone de: una neurona intra-retiniana bipolar; una neurona retinoganglionar multipolar, o retino-diencefálica; y una neurona intracerebral, diencefalo-cortical. Pues bien, respecto a la neurona retino-diencefálica, hay que tener en cuenta, que las fibras pupilares que unen la retina con los núcleos de la acomodación y de la convergencia, caminan también por la vía óptica y con ella llegan

al diencéfalo, pudiendo aquí desencadenar un desequilibrio diencefálico, del que me ocupo a continuación.

A la vista de estos cinco apartados anteriores, se puede concluir con REIN, que la misión del Diencéfalo, es la de “conjuntar las funciones de los demás centros vegetativos” y según las investigaciones de HESS, que el diencéfalo está organizado para la “realización de funciones”. Es decir, el diencéfalo es el lugar donde convergen todas las funciones sensoriales, sensitivas, vegetativas, psíquicas, etc. y donde son susceptibles de conexionarse y coordinarse unas con otras, y todas entre sí.

Si en el individuo normal, todas estas funciones mantienen un perfecto equilibrio, este equilibrio se pierde cuando se altera cualquiera de aquellas, sea el que fuere el motivo (infeccioso, tóxico, traumático, alérgico, nervioso, “refractivo”, olfatorio, emotivo, psíquico, metabólico, hormonal, etc.), apareciendo un desequilibrio de una o varias de las funciones restantes, dando origen a cuadros patológicos diversos, tales como la cefalea, con el cortejo de síntomas que la acompañan, y entre los que también encontramos con frecuencia: Cambios de carácter, variaciones del humor con tendencia a la desidia y pesimismo (MARQUEZ), tendencias criminales, (que los autores italianos designan con el nombre de “diencéfalo-endocrinosis-criminogénicas”), crisis sudorales hipnóticas o incluso febriles (estas últimas que no obedecen a ningún proceso flogístico ni infeccioso, que el Internista no sabe a qué atribuir y que ceden espectacularmente casi, al corregir con gafas una ametropía que presentaba el paciente;) alteraciones gástricas o renales, etc.

Dada pues esta multiplicidad enorme de conexiones de todas las porciones constituidas del diencéfalo, podemos explicarnos ahora, por ejemplo, por qué en las emociones, una simple tensión psíquica excesiva, actuando a través del diencéfalo sobre las glándulas de secreción interna, y por intermedio de éstas sobre los troncos vasculares, pueden alterar la nutrición de diversas zonas orgánicas (corteza cerebral, retina, coroides, circulación periférica, etc.); por qué de igual manera, un trastorno trófico de las fibras parasimpáticas que caminan, por ejemplo, por el fascículo tálamo-óptico de FREY, puede ocasionar alteraciones vasculares; por qué un alérgeno cualquiera puede actuar sobre las glándulas de secreción interna, e incluso, por qué éstas últimas presentan en ocasiones, alterada su secreción.

Es cierto, según B. CARRESRAS MATAS, que las glándulas endocrinas ejercen una clara influencia sobre el ojo (lo mismo que sobre todo el organismo en general) y se pone en duda el concepto recíproco, o sea, que el ojo pueda actuar sobre el sistema hormonal, aunque conocemos una influencia indirecta a través de lo que llamaba MARAÑÓN la “Conmoción visceral”. No obstante,

yo creo que, sea de una u otra manera, esta influencia inversa existe (sobre todo clínicamente), aun cuando muchas veces no podamos explicar cuáles son sus vías, o se nos escape su manifestación, y DIAZ DOMINGUEZ explica cómo un estímulo visual puede actuar sobre los centros diencefálicos.

Es decir, que para nosotros el diencefalo, con todas sus innumerables series de conexiones conocidas y menos conocidas, pero existentes, sería el único capaz de explicarnos todas las alteraciones orgánicas y funcionales que puede desencadenar un defecto de refracción ocular (sobre todo los astigmatismos pequeños en mi experiencia).

### 2º *La "hipermetropía"*.

Aquí el eje anteroposterior del globo ocular resulta corto, y en su consecuencia los rayos visuales que penetran en el ojo se reúnen en un punto situado más atrás de la retina; para obviar este inconveniente entra en acción el músculo ciliar aumentando la curvatura y poder refringente del cristalino, adelantando entonces la imagen. Ahora bien, en la visión próxima, los rayos que penetran en el ojo no tienen un trayecto paralelo (como se considera que traen los de visión lejana), sino divergente, y por tanto, su unión, una vez refractados, se realizará mucho más posteriormente al nivel que ocupa la retina y en su consecuencia, el ojo, para evitarlo, ha de poner en juego una potencia acomodativa mucho mayor, con lo que la fatiga o astenopia, también se intensificará traduciéndose en cefaleas.

### 3º *En la "Miopía y la Presbicia"*.

Con visión binocular bien compensada (si no hay además un desequilibrio muscular sobreañadido), no suelen manifestarse de forma frecuente cefaleas acomodativas. En el primero de los defectos, porque no aparece la acomodación por estar el punto focal anterior del sistema de refracción, muy cerca; en el segundo, porque la esclerosis del cristalino y la rigidez que ésta le infunde, impide la acomodación.

### 4º *En la "Aniseiconia"*.

Es decir, en los casos que en la imagen de un mismo objeto tiene forma o tamaño diferente en cada ojo del mismo sujeto que la capta, la acomodación y los movimientos de fusión han de actuar para tratar de igualarlas lo más posible en la acomodación, aumentando o disminuyendo el poder de refringencia del sistema óptico de uno de los ojos, que consiga eliminar o disminuir al máximo la diferencia de tamaño (miopía, hipermetropía), e incluso de forma (astigmatismo) de las imágenes, y la fusión, para que dichas imágenes se pinten en puntos retinianos correspondientes.

Si bien la diferencia de refracción entre uno y otro ojo (anisometropía) menores de un 5%, suelen tolerarse bien gracias precisamente a esos movimientos neutralizadores, cuando esta diferencia es superior, la compensación fisiológica espontánea, resulta cada vez más difícil y solo puede conseguirse, y no siempre a costa de un esfuerzo que ocasiona una fatiga (astenopia), a su vez con cefaleas persistentes.

B) *Los trastornos motores oculares.*

El desequilibrio muscular binocular, determina las Heteroforias. La posición de los ejes antero-posteriores de los globos oculares en estado de reposo absoluto, coincide con la de los ejes orbitarios, es decir, ligeramente hacia fuera; por tanto, el paralelismo que adopten los ejes visuales durante la visión lejana se consigue ya merced a una "acomodación fisiológica" mínima pero necesaria, para obtener la visión binocular, por lo que, para la visión lejana y en condiciones normales, puede aceptarse que la acomodación está en "reposo funcional". Según A. ALVAREZ y otros autores, estas dos funciones (dirección de los ejes visuales y acomodación) son equivalentes para la misma distancia de visión y tanto, pues, se acomoda en dioptrías, como se converge en ángulos metro.

Pero en la fisiología de la visión binocular hay que tener, además, en cuenta dos importantes propiedades del ojo, una, que se conoce con el nombre de "amplitud relativa de la acomodación", que consiste en poder aumentar o disminuir la acomodación sin variar la vergencia, teniendo ésta adaptada para una determinada distancia; y otra que se conoce con el nombre de "amplitud relativa de vergencia" (convergencia o divergencia), que consiste en poder aumentar o disminuir la vergencia de los dos ejes visuales, manteniendo invariable la acomodación. Estas dos amplitudes compensan mutuamente sus trastornos respectivos, y permiten la visión binocular dentro de sus recorridos, pero sobre todo es la convergencia la que resulta más influenciada por los trastornos primitivos de la acomodación.

Ahora bien, en las alteraciones de la hipermetropía y de la miopía, que tanta influencia tienen en la convergencia y en la divergencia, la variación de la amplitud relativa de la acomodación no suele ser equivalente a la convergencia, pues en caso contrario habría armonía, y no aparecerían trastornos. Y así, pues, en la hipermetropía, la convergencia suele estar aumentada en grado superior al de la acomodación, al tratar con esta de neutralizar el vicio refractivo. En la miopía, como casi no se necesita la acomodación para cerca, o aparece un exceso de la convergencia (que resulta necesario para la visión a las cortas distancias que suelen utilizar los míopes en la visión de cerca) o esta convergencia no actúa (por agotamiento, por debilidad en la excitación, o por alargamiento de los globos oculares).

Por lo que se refiere a la visión binocular, pues, los ojos han de adaptar su acomodación y la dirección de los ejes visuales al punto que miran, debido a que para conseguirla se precisa que las imágenes se pinten en puntos retinianos fisiológicamente equivalentes en cada ojo, o lo que es lo mismo, en puntos retinianos topográficamente o correspondientes, pudiendo pues aparecer:

1. Un equilibrio Muscular Perfecto, en cuyo caso hay una convergencia normal u "ortoforia".

2. Un Desequilibrio Muscular de las funciones de Convergencia-Divergencias, pero compensado, merced a que una de ellas es capaz de neutralizar el exceso de la opuesta o antagónica, de forma que se logra mantener la dirección de los ejes visuales hacia el punto acomodado y por tanto la visión binocular, recibiendo entonces el nombre de "heteroforia".

3. Un Desequilibrio Muscular de las funciones Convergencia-Divergencias, en el que no resulta posible la compensación, porque una de esas funciones carezca de capacidad suficiente para compensar el exceso de la otra, no pudiendo conseguirse entonces la visión binocular y dando paso pues, al "estrabismo concomitante", en el que un ojo es el que ve y fija, y el otro se desvía.

Pues bien, el segundo de los casos es causa muy frecuente de cefaleas constantes.

C) *Enfermedades oculares que cursan con cefaleas:*

1º Afecciones de la órbita:

a) Celulitis orbitaria (luética, tóxica, secundaria, a un proceso de la vecindad, etc.), en la que el ojo se propulsa e inmoviliza, y pueden estar infiltrados la musculatura extra-ocular y los pares craneales III, IV y VI.

b) Hematomas retrobulbares, generalmente traumáticos o quirúrgicos.

c) Fracturas Orbitarias.

d) Exoftalmos de toda índole, en que tanto la musculatura extrínseca ocular, como el nervio óptico, sufren sendos estiramientos.

e) Seudomotor y granuloma postraumático.

f) Tumores de la órbita: carcinomas de glándula lagrimal, glioma meningioma del nervio óptico, meningioma y osteosarcoma de las paredes orbitarias, tumores de las estructura circundantes, neuroblastoma, cloroma, carcinoma secundario, etc.

2º *Inflamaciones del globo ocular:*

Oftalmía panoftalmía; iritis, Iridociclitis y Uveitis de diversos etiologías.

3º *Hipertensiones oculares.*

Glaucoma agudo y crónico, tanto primario como secundarios (catarata traumática, iritis hipertensiva, hemorragia masiva en vítreo, tumor intraocular fundamentalmente retinoblastoma, etc.).



4º *Alteraciones de la vía sensitiva del aparato visual.*

Motivadas por traumatismo del globo ocular, por las afecciones oculares arriba mencionados, o de sus anexos, entre las que figuran: traumatismos y heridas, dacriocistitis agudas, abscesos de ceja y orzuelos palpebrales, conjuntivitis agudas y escleritis; quemaduras, heridas, erosiones, úlceras y cuerpos extraños conjuntivales y aún más, corneales. Todos ellos por regla general, además de la sintomatología específica ocular, se acompañan de cefaleas de mayor o menor grado.

Se explican estas cefaleas debidas a enfermedades oculares, si se tiene en cuenta que: Anatómicamente tanto la inervación exo como endocraneal están formadas por una parte de los nervios craneales y raquídeos del sistema cerebroespinal y por fibras simpáticas y parasimpáticas que suelen acompañar a las arterias y sobre todo, que la primera, la exocraneal, extiende su red por los tejidos epicraneales, así como por el periostio y el hueso.

Estas múltiples inervaciones se relacionan íntimamente con las de las partes no craneales de la cabeza, entre las que hay que contar la órbita, el ojo y sus anejos, en los que ciertas contexturas anatómicas favorecen la irradiación y repercusión de las causas patológicas que desencadenan las cefaleas.

D) Dentro del concepto general de cefaleas y por considerar las entidades nosológicas muy caracterizadas, si bien relacionadas sólo de una forma indirecta y exclusivamente en lo que concierne a su sintomatología a la oculística, deben citarse: la jaqueca simple o hemicraneal, la jaqueca oftálmica (teicopsia o escotoma centelleante) cuya etiología más aceptada es la vascular, siendo, eso sí, muy interesante señalar como agente desencadenante a veces, los desequilibrios diencefálicos (más arriba ya expuestos), desencadenados a su vez muchas veces, por pequeños defectos de refracción (sobre todo astigmatismos, no nos cansaremos de repetirlo); la jaqueca oftálmica, la cefalea orbito-frontal unilateral por acúmulos (BARRAQUER BORDAS); la neuralgia del trigémino; las simpatalgias; el síndrome neuro-oftálmico por espondilopatía cervical (del que nunca debe olvidarse el Oftalmólogo ante un paciente que consulta por cefaleas).

***CARACTERISTICAS DE LAS CEFALIAS OCULARES.***

A) Cefaleas de etiología refractiva (por defecto de refracción). En las producidas por defectos congénitos (como el astigmatismo y la hipermetropía), suelen aparecer ya en la edad escolar, y según mi experiencia más frecuente en la juventud primera, aunque pueden hacer presencia también en cualquier otra si aparecen nuevas modificaciones fisiológicas o necesidades visuales.

Estas cefaleas suelen guardar relación con los trabajos visuales (cine, televisión, trabajos de visión próxima, tareas escolares, etc.) y por tanto pueden acentuarse en el transcurso del día. Más adelante, sobre todo al aumentar la edad del paciente, la cefalea suele manifestarse ya desde el momento de despertar por la mañana, por resultar ya insuficiente el número de horas de descanso y sueño nocturno, para comenzar la nueva jornada completamente descansado. De todas formas, el grado de intensidad y la frecuencia de tales cefaleas, puede variar mucho de unos individuos a otros, y de unas edades a otras, según el equilibrio funcional y orgánico de cada uno, y muy especialmente en el sexo femenino.

Las cefaleas que estamos estudiando, suelen referirlas localizadas los pacientes por orden de frecuencia, en la región frontal y fronto-parietal, en la occipital, en las regiones periorbitarias y en los propios globos oculares, así como en el vértex craneal. Las describen por lo común, como dolores sordos, con sensación de presión ocular, pesadez de párpados y somnolencia y también de fatiga; otras veces, (las menos), los dolores llegan a ser más intensos, con frecuencia, todo ello se acompaña de turbidez visual, desplazamiento de los objetos, diplopia transitoria, etc. y solo en ocasiones, sensación de mareo.

B) Cefaleas producidas por desequilibrios oculo-motores (heteroforias): Sus características más destacables son: que pueden aparecer en cualquier edad; que su intensidad guarda relación con la distancia de visión, y así, en la exoforia en que divergen los ejes visuales, las cefaleas se acentúan en los trabajos de cerca; en la eso o endoforia, en que convergen los ejes visuales, las cefaleas son más frecuentes acusadas en la visión de lejos.

Cuando este desequilibrio muscular ya que no puede ser compensado espontáneamente (por fatiga o por edad), aparece la diplopia.

Tanto en el apartado A como en el B, además de las características propias de las cefaleas, se puede descubrir en muchos casos una disminución de la agudeza visual, en otros no, y en estos últimos es donde más trabajo le cuesta al Oftalmólogo convencer al paciente del origen verdadero de sus cefaleas, y de que el único medio de evitarlas y de suprimirlas es el uso de una gafas (que muchas veces deben llevarse constantemente puestas), teniendo que recurrir a las mejores dotes de persuasión, que aún así con frecuencia se ven fallidas, porque el paciente, no sin razón, sigue afirmando que ve bien.

C) Las cefaleas producidas por enfermedades oculares que irritan la vía sensitiva del aparato visual, son mucho más fáciles de diagnosticar, pues se acompañan de algias y otros síntomas locales suficientemente expresivos como para que el paciente se dirija por sí mismo a consultar con el Oftalmólogo, o a él le remita el Médico que le asiste, según los antecedentes o evolución del proceso.

### *DIAGNOSTICO:*

El diagnóstico de las cefaleas de etiología ocular, se realiza como es natural, por la anamnesis y los resultados de la exploración anatómica y fisiológica ocular completa (inspección, palpación, percusión, refractometría, biomicroscopía, tonometría y oftalmodinamometría oftalmoscopia, campimetría, exoftalmometría, radiografías de órbitas y globos oculares, análisis clínicos, y todas las demás técnicas auxiliares complementarias existentes.

### *DIAGNOSTICO DIFERENCIAL*

A) Las cefaleas refractivas y acomodativas son:

- 1º las de los procesos sinusales de la vecindad orbitaria.
- 2º las de los procesos dentarios con algias irradiadas .
- 3º las de los trastornos hepato-biliares, orgánicos o funcionales (retención biliar, estreñimiento, etc.) en estos casos, además de cefaleas, el paciente suele acusar miodesopsia (moscas volantes) y otra sintomatología sobreañadida que debe buscarse.
- 4º las de hipertensión arterial, en la que también debe buscarse, miodepsias y escotomas centelleantes, con otros síntomas que les son propios a la enfermedad.
- 5º las de hipertensión craneal.
- 6º las debidas a trastornos óseos, ligamentosos o musculares de la columna cervical.

B) De las cefaleas producidas por enfermedades oculares y alteraciones de la vía sensitiva del aparato visual, entre sí, ello es de la competencia del Oftalmólogo, quien tiene múltiples y variados elementos de diagnóstico, para poder diferenciar unas de otras.

### *PRONOSTICO:*

A) En las cefaleas refractivas y acomodativas el pronóstico es bueno, tanto orgánico como funcional, dependiendo todo o casi todo, de que el paciente lleve a cabo el tratamiento óptico (corrección del defecto de refracción, o del vicio de acomodación).

B) En las cefaleas causadas por enfermedades oculares intrínsecas o de la vecindad, el pronóstico depende de la evolución del proceso etiológico en cada caso.

*TRATAMIENTO*

A) De las cefaleas refractivas: Puesto que la curación de los defectos de refracción, en la mayoría de los casos no es posible aún hoy en día, ni médica ni quirúrgicamente, de una forma total y definitiva, no tenemos otro tratamiento que la "corrección" de los mismos, supliéndolos o contrarrestándolos mediante sistemas ópticos (gafas y sus derivados microlentillas, lentes de inclusión intraocular, corneales o camerulares, etc.), que según el defecto y edad del paciente, usará para visión lejana, para la próxima, para ambas o una misma corrección para todo. Un porvenir esperanzador se apunta con la nueva terapéutica de los defectos de refracción, ideada por BARRAQUER MONER J. I. a base de su intervención quirúrgica denominada queratomileusis.

Conviene hacer constar que en los casos en que la cefalea tiene como causa la distinta forma o tamaño de las imágenes retinianas de cada ojo, a la vez que establece el tratamiento etiológico que normalice los mecanismos de formación de las imágenes en la retina, hay que emplear cristales "aniseicónicos" que las igualen.

B) De las cefaleas acomodativas: Una insuficiencia acomodativa puede curarse actuando sobre la causa o causas que la producen. Así por ejemplo, cuando la causa de una heteroforia es un defecto de refracción, en muchos casos al corregir éste con gafas, cede aquella. Otras veces la causa es un trastorno de la visión binocular por un déficit funcional neuro-muscular ocular, y en este caso habrá que elevar el tono muscular con el tratamiento medicamentoso adecuado, con ejercicios ortópticos en ocasiones, y auxiliándose en muchos casos, además de con la corrección previa del defecto de refracción, con cristales prismáticos.

C) El tratamiento de las cefaleas causadas por afecciones oculares propiamente dichas, de sus anexos, orbitarios, etc., debe ser como lógicamente se deduce, el causal y éste cae de lleno dentro del campo visual de la propia oftalmología con toda la terapéutica medicamentosa, técnicas físicas y quirúrgicas y sus indicaciones precisas.

*BIBLIOGRAFIA:*

- 1 Cefaleas de origen ocular-Rev. de Inf. Med. Terap. año XXII, Nº 21-22 1.947. Alvarez Alvarez.
- 2 Jaquca Oftálmica - Arch. Soc. Oft. Hisp. Amer. T. XV, Nº 12. 1955. I. de V. Gamazo, Pág. 1. 347 a 1.385.
- 3 Introducción a la Clínica del diencefalo. Gaceta sanitaria año XII, Nº 4-5. 1.957.
- 4 Neuro-oftalmología, Guillaumat, Morax y Offret. Masson et cie 1.959.

- <sup>5</sup> Hemicrania y otras cefaleas. *Medicina Clínica*. Año XV-T. XXIX N° 1.
- <sup>6</sup> Jaqueca oftálmica. *Medicamenta*. Año XVIII. N° 358. 15 agosto 1.960 Piñero Carrión.
- <sup>7</sup> Jaqueca en niños. *Triángulo Sandoz*. Vol. V., N° 1. Junio 1.961.
- <sup>8</sup> *Patología Médica Oftalmológica (Oftalmología sistemática)*. Sorsby Ed. Toray. Barcelona. 1.962.
- <sup>9</sup> Diagnóstico diferencial y orientaciones terapéuticas de las cefaleas. Barraquer Bordás. *Acta O.R.L. Iber. Amer.* XVI, 4-353, 388, 1.965.
- <sup>10</sup> *Exploración y sintomatología oftalmoneurológica.*—Palomar. Ed. Palestra. Barcelona. 1.965.
- <sup>11</sup> *Encyclopedia Médico-Chirurgicales. Ophtalmologia.* T.III. —570 a 30, 2c y 590— A 10, 1 f.

Orellana, 1 Madrid, 4 España.

## ESTUDIO COMPARATIVO ENTRE APLANOTONOMETRIA DE GOLDMANN E MAKLAKOV EM 100 OLHOS NORMAIS

POR

MARILIA DOS SANTOS AYRES, M. D.

Goiânia - Brasil

### INTRODUÇÃO

A aplanotometria é baseada na lei de Imbert (1885) e Fick (1888) que assim se expressa: “a pressão existente dentro de uma esfera cheia de líquido, cercada por uma membrana flexível e infinitamente fina, é medida pela contração externa necessária para aplanar determinada área de esfera” <sup>3</sup>.

“Quando revemos a história da tonometria, diz Hilton Rocha <sup>12</sup> um lugar destacado deve ser reservado a Maklakov que, em 1885, deu um dos primeiros gritos em prol da tonometria instrumental”.

Para Imbert, engenheiro de Lyon, o único que, em 1885, penetrou o alcance do princípio em que se baseou Maklakov na feitura do seu tonômetro, o novo instrumento teve esta consequência: “le seul croyons nous que repose sur une interprétation rationnelle du phénomène à mesurer” <sup>2</sup>.

Maklakov foi o criador da aplanotometria e também o precursor das estações de aferição de tonômetros construiu uma escala para medir a área aplanada <sup>2</sup>. Em homenagem ao sábio russo transcrevemos estas suas palavras, tão sábias quanto modestas, “on voit d’après les descriptions données que, dans les trois modèles, je me suis efforcé d’éliminer le frottement qui est le plus grand ennemi de la sensibilité ou de l’exactitude de l’appareil. Je n’ai pas la moindre intention d’attribuer à l’instrument une précision irréprochable. Je sais bien qu’il a des défauts. Je n’attribue de valeur qu’au principe qui m’a guidé: si ce principe est juste, on peut perfectionner l’instrument” <sup>7</sup>.

A apresentação do tonômetro de impressão, em 1905, por Hjalmar Schiötz, à Sociedade Norueguêsa de Oftalmologia, despertou interesse do mundo ocidental, que esqueceu, por completo, o tonômetro de Maklakov.

Deve-se a Friedenwald, 1939, a divulgação dos trabalhos de Kalfa que juntamente com o Professor Filatov aperfeiçoou o tonômetro de Maklakov, tornando-o mais completo, mas dentro do princípio de Maklakov.

Os resultados obtidos pelos dois métodos, Maklakov e Schiötz, *are thus capable of confirming and supporting each other.*

Os estudos de Filatov-Kalfa culminaram na versão hoje conhecida do tonômetro de Maklakov, apresentado com os pesos 5, 7.5, 10 e 15 gramas. Friedenwald quando tomou conhecimento dos resultados obtidos por Kalfa não hesitou em afirmar: — “the validity of both methods is supported by widespread agreement in clinical observations achieved independently”<sup>2</sup>. Kalfa trabalhara de 1926 a 1936 com o tonômetro de Maklakov mas seus estudos, não fossem Friedenwald que os revelou em 1939, continuariam ignorados do mundo ocidental porque o tonômetro de Schiötz dominou o cenário clínico do ocidente e a seguir os trabalhos de Friedenwald despertaram a atenção geral com a sua pesquisa reavaliando, por meio de novas tabelas, a tonometria pelo Schiötz e permitindo a pesquisa da rigidez escleral pelo nomograma e pelas tabelas que meticulosamente elaborou.

A despeito dos trabalhos de Friedenwald a idéia basilar lançada por Maklakov continuava de pé e em 1954 Hans Goldmann apresenta o seu tonômetro de aplanção em torno do qual iriam girar tôdas as pesquisas para aferir os resultados obtidos pelo método de Schiötz e pelo tonômetro de Maklakov.

Posner foi o divulgador no mundo ocidental do tonômetro de Maklakov, na sua versão Filatov-Kalfa, modificando a escala de conversão de Golovine e Poliakov em 1962, ambas distribuídas com o aparelho, pela Instruments Specialties Company (860 Riverside Drive. New York - N. Y.) onde adquirimos o nosso, de fabricação soviética.

Posner continuando seus estudos com Richard Ingham terminou por lançar o “Applanometer” de Posner-Ingham, testado por Gloster e Martin que achou resultados discordantes (5) dos obtidos por seus autores<sup>8,11</sup>.

Casanovas, Quintana e Menezo, em trabalho conjunto<sup>1</sup> foram os introdutores do tonômetro de Maklakov na Espanha.

“Nosotros —assim se expressam<sup>1</sup>— hemos comparado en 27 pacientes las cifras obtenidas con la tonometria corregida (tonômetro de Schiötz) el tonômetro de Goldman y el de Maklakov. Las diferencias halladas son mínimas”.

## MATERIAL E METODO

Nossa amostra consta de 100 olhos selecionados, tendo acuidade visual igual a um, sem correção, aparentemente normais, sem alterações da conjuntiva ou da córnea. Recrutamos os examinandos entre alunos do 4º ano do Curso Médico, e entre jovens, candidatos à carreira de oficialato de Polícia Militar do Estado de Goiás, aproveitando ainda alguns pacientes do Ambulatório de Oftalmologia do Hospital Geral da Faculdade de Medicina da UFG.

Rejeitamos os casos que devido à fase de estabilização nos levavam a supor massagem ocular além do normal o que devia alterar o resultado desejado. Eliminamos também aqueles que fizeram boa aplanção pelo Goldmann e depois não se comportavam como era desejado quando submetidos à aplanotometria pelo Maklakov. As leituras foram obtidas entre as 8 e as 12 horas.

Tomamos as medianas de três medidas feitas com o tonômetro de Goldmann e imediatamente a seguir com o de Maklakov, do qual tomamos sempre duas medidas para cada olho, usando os dois lados do pêso em exame, e destas aceitamos as de configuração mais regular e rejeitávamos as medidas discordantes entre si, fazendo imediatamente novas leituras.

*Tonometria de Aplanção de Goldmann*

Usamos o tonômetro de Goldmann adaptado à lâmpada de fenda Haag-Streit 900, com ângulo constante de 60° em relação ao eixo luminoso, fazendo-se a observação com aumento de dez vezes e empregando a ocular direita.

A córnea era anestesiada pela Tetracaina a 0.5% e a seguir instalava-se colírio de Fluoresceína. Paciente comodamente assentado e olhando a certa distância, um ponto na parede, atrás de nós, para evitar acomodação e manter melhor abertura palpebral. O compressor é mantido em frente à córnea, sem tocá-la, por uns instantes, e só depois fazíamos a medida, ajustando antes o tambor para uma força inicial de 10 g.

A mediana não devia diferir de mais de 1 mmHg entre as três medidas sucessivas, esperando, quando necessário, a fase de estabilização<sup>8</sup>.

*Tonometria pelo aplanômetro de Maklakov*

Usamos o modelo Filátov-Kalfa, de fabricação soviética, com a tabela de Posner (8 1962), que acompanha o instrumento, distribuído nos USA.



Notamos, através da balança elétrica de precisão de Mettler, os seguintes valores: pêso 5 g do aparelho pesando menos 17 mmg e os dois outros (de 7.5 e 10) pesando mais 15 mmg.

As leituras foram primeiramente tomadas com o aparelho de Goldmann, paciente assentado, e imediatamente a seguir, com o doente em decúbito dorsal tomamos as leituras com os pesos 5, 7.5 e 10 g.

As leituras com o aparelho de Filátov-Kalfa demoravam fração de segundo, tomadas no vértice da córnea, com olho no vertical, e logo eram registradas em papel levemente embebido em álcool. Se as duas impressões obtidas de cada olho não apresentavam aspecto uniforme eram tomadas duas novas medidas. A leitura era feita com a escala transparente de Posner, que nos dá a leitura imediata, podendo fazer-se a leitura com maior precisão usando lente milimetrada com aumento de 7 (Quintana <sup>13</sup>) vêzes ou como fazem Posner-Inglima <sup>11</sup> da área aplanada.

O corante usado para a tomada da área aplanada era a fórmula de Kalfa: — Argirol 2 g. — Agua destilada 2 cc e Glicerina 2 cc.

Esta mistura é usada da seguinte maneira: numa almofada das usadas para os carimbos colocamos algumas gotas para embeber o conjunto e depois aplicamos as suas extremidades de cada pêso, de maneira a obter uma impregnação uniforme no vidro despolido e a seguir aplicamos extremidades no vértice da córnea. A extremidade do pêso aplicada na córnea apresenta uma área central escura circundada de uma área circular branca, limite da área aplanada, cujo diâmetro é medido para tabela de Posner ou então aplicamos a escala de plástico transparente, que nos dá diretamente a medida em mmHg.

Embora tenhamos feito as leituras com os pacientes deitados a aplanotometria de Maklakov pode ser feita com o examinando em posição de recúbito, como se faz com o Schiötz, levemente recostado, no suporte para a cabeça do cadeira do equipo, ou outra qualquer, não havendo neste caso grandes alterações de posição nas leituras.

APLANOTONOMETRIA

OBSERVAÇÕES PESSOAIS

Casos	Nome	Idade	Côr	Goldmann	Maklakov	Peso 5	7.5	10
1	D.F.C.	27	L.	OD 10		10.5	12	15
				OE 10		10.5	12	15
2	M.A.T.	17	L.	OD 12		12	13	15
				OE 12		12	13	15
3	E.D.T.	34	L.	OD 10		10.5	13	15
				OE 10		10.5	13	15
4	M.S.S.	34	L.	OD 12		12	13	15
				OE 12		12	13	15
5	M.E.J.	20	L.	OD 12		13	14	15
				OE 12		13	14	15
6	C.X.C.	32	L.	OD 12		12	14	15
				OE 12		12	14	15
7	M.A.V.	25	L.	OD 10		10.5	12	15
				OE 12		12	14	15
8	A.R.S.	19	M.	OD 10		10.5	12	15
				OE 10		10.5	12	15
9	R.M.	20	L.	OD 12		12	14	15
				OE 12		12	14	15
10	A.M.P.	26	L.	OD 20		20	22	23
				OE 20		20	22	23
11	J.L.A.	20	L.	OD 16		16.5	18	19
				OE 16		16.5	18	19
12	J.B.F	20	F.	OD 16		16.5	18	19
				OE 16		16.5	18	19
13	A.R.A	22	L.	OD 16		16.5	18	19
				OE 16		16.5	18	19
14	F.P.F.	25	L.	OD 14		15	16.5	17
				OE 14		15	16.5	17
15	P.L.S.	20	L.	OD 16		14	15	17
				OE 16		14	15	17
16	L.A.	22	F.	OD 14		14	15	16
				OE 14		14	15	16
17	S.S.S.	22	M.	OD 14		15	16.5	17
				OE 14		15	16.5	17
18	J.A.	26	L.	OD 14		14	15	16
				OE 14		14	15	16
19	C.S.	22	F.	OD 16		15	16.5	17
				OE 16		15	16.5	17
20	D.M.M.	20	F.	OD 14		14	15	16
				OE 14		14	15	16

## MARILIA DOS SANTOS AYRES

<i>Casos</i>	<i>Nome</i>	<i>Idade</i>	<i>Côr</i>	<i>Goldmann</i>	<i>Maklakov</i>	<i>Peso 5</i>	<i>7.5</i>	<i>10</i>
21	N.S.S.	27	F.	OD OE	16 16	16.5 16.5	18 18	19 19
22	I.G.L.	20	L.	OD OE	18 18	18 18	18 18	19 19
23	R.A.R.	20	F.	OD OE	16 16	16.5 16.5	18 18	19 19
24	O.M.P.	25	M.	OD OE	16 16	16.5 16.5	18 18	19 19
25	J.L.C.	19	L.	OD OE	12 12	13 13	15 15	16 16
26	A.F.S.	20	L.	OD OE	14 14	14 14	15 15	16 16
27	Z.B.	30	L.	OD OE	12 12	13 13	13 13	15 15
28	J.C.M.	24	L.	OD OE	12 12	13 13	15 15	16 16
29	J.V.R.	24	L.	OD OE	10 10	10.5 10.5	12 12	15 15
30	W.A.O.	21	L.	OD OE	12 12	12 12	13 13	15 15
31	F.M.S.	21	L.	OD OE	12 12	12 12	13 13	15 15
32	R.A.C.	21	L.	OD OE	12 12	12 12	14 14	16 16
33	R.P.S.	26	F.	OD OE	14 14	14 14	15 15	16 16
34	A.M.O.	24	L.	OD OE	12 12	12 12	12 12	15 15
35	E.A.B.	28	L.	OD OE	12 12	12 12	12 12	15 15
36	L.M.L	35	L.	OD OE	18 18	20 20	20 20	21 21
37	M.C.G.	25	L.	OD OE	14 14	14 14	15 15	16 16
38	J.D.M.	20	L.	OD OE	12 12	13 13	14 14	15 15
39	F.F.C.	29	L.	OD OE	22 22	22 22	22 22	23 23
40	M.O.F.	16	L.	OD OE	14 14	14 14	14 14	16 16
41	M.Z.S.	15	L.	OD OE	14 14	14 14	15 15	16 16

APLANOTONOMETRIA

Casos	Nome	Idade	Côr	Goldmann	Maklakov	Peso 5	7.5	10
42	A.M.	23	L.	OD	18	18	18	19
				OE	18			
43	F.C.B.	27	L.	OD	12	12	12	15
				OE	12			
44	W.C.	25	L.	OD	10	10.5	12	15
				OE	10			
45	N.A.	23	L.	OD	14	14	14	15
				OE	14			
46	S.S.	22	L.	OD	18	18	18	17
				OE	18			
47	L.G.G.	24	F.	OD	14	14	14	15
				OE	14			
48	M.F.S.	15	F.	OD	14	12	14	15
				OE	14			
49	L.M.L.	26	L.	OD	18	18	18	19
				OE	18			
50	O.M.L.	22	L.	OD	16	16.5	16.5	17
				OE	16			
100	Olhos Media				13.92	14.21	15.20	16.62

*Frecuência dos valores pressão intraocular em mmHg.*

Po	Goldmann	Maklakov pêsos 5	7.5	10
10	12	—	—	—
10.5	—	12	—	—
12	30	20	18	—
13	—	10	10	—
14	28	24	18	—
15	—	6	20	42
16	16	—	—	22
16.5	—	14	8	—
17	—	—	—	12
18	10	8	20	—
19	—	—	—	18
20	2	4	2	—
21	—	—	—	2
22	2	2	—	—
23	—	—	—	4
Total	100	100	100	100

Figura 1

*Distribuição pela idade e percentagem por grupo etário.*

<i>Grupo etário</i>	<i>Pacientes</i>	<i>Percentagem</i>	<i>Nº de Olhos</i>
15—19 años	6	12%	12
19—23	21	42%	42
23—27	16	32%	32
27—30	3	6%	6
30—34	3	6%	6
34—38	1	2%	2
Total	50	100%	100

**Figura 2**

*Médias de Po obtidas em 100 leituras com os tonômetros de  
Goldmann e Maklakov pêso 5 - 7.5 e 10*

<i>Método</i>	<i>Po média</i>	<i>Diferença entre Goldmann e Maklakov</i>
Goldmann	13.92	
Maklakov pêso 5	14.21	0.29
Maklakov pêso 7.5	15.20	1.28
Maklakov pêso 10	16.62	2.70

**Figura 3**

APLANOTONOMETRIA

*Conversion tables for Maklakov applanation tonometer*

Calibration by Adolph Posner, M. D.

<i>Diameter (mm)</i>	<i>Pressure in mm. Hg.</i>		
	<i>Intraocular 5 grams</i>	<i>7.5 grams</i>	<i>10 grams</i>
3.0	60	80	120
3.1	55	75	105
3.2	50	70	96
3.3	47	66	90
3.4	44	62	84
3.5	41	58	79
3.6	39	55	74
3.7	37	52	69
3.8	35	49	65
3.9	33	46	61
4.0	32	44	58
4.1	30	42	55
4.2	29	40	52
4.3	27	38	49
4.4	26	36	46
4.5	25	34	43
4.6	24	32	41
4.7	23	30	39
4.8	22	29	37
4.9	21	27	35
5.0	20	26	34
5.2	18	24	31
5.4	16.5	22	28
5.6	15	20	25
5.8	14	18	23
6.0	13	16.5	21
6.2	12	15	19
6.4	11	14	17
6.6	10.5	13	16
6.8	10	12	15

Figura 4 — Tabela que usamos.





Figura 6 — Tonômetro de Goldmann que usamos.



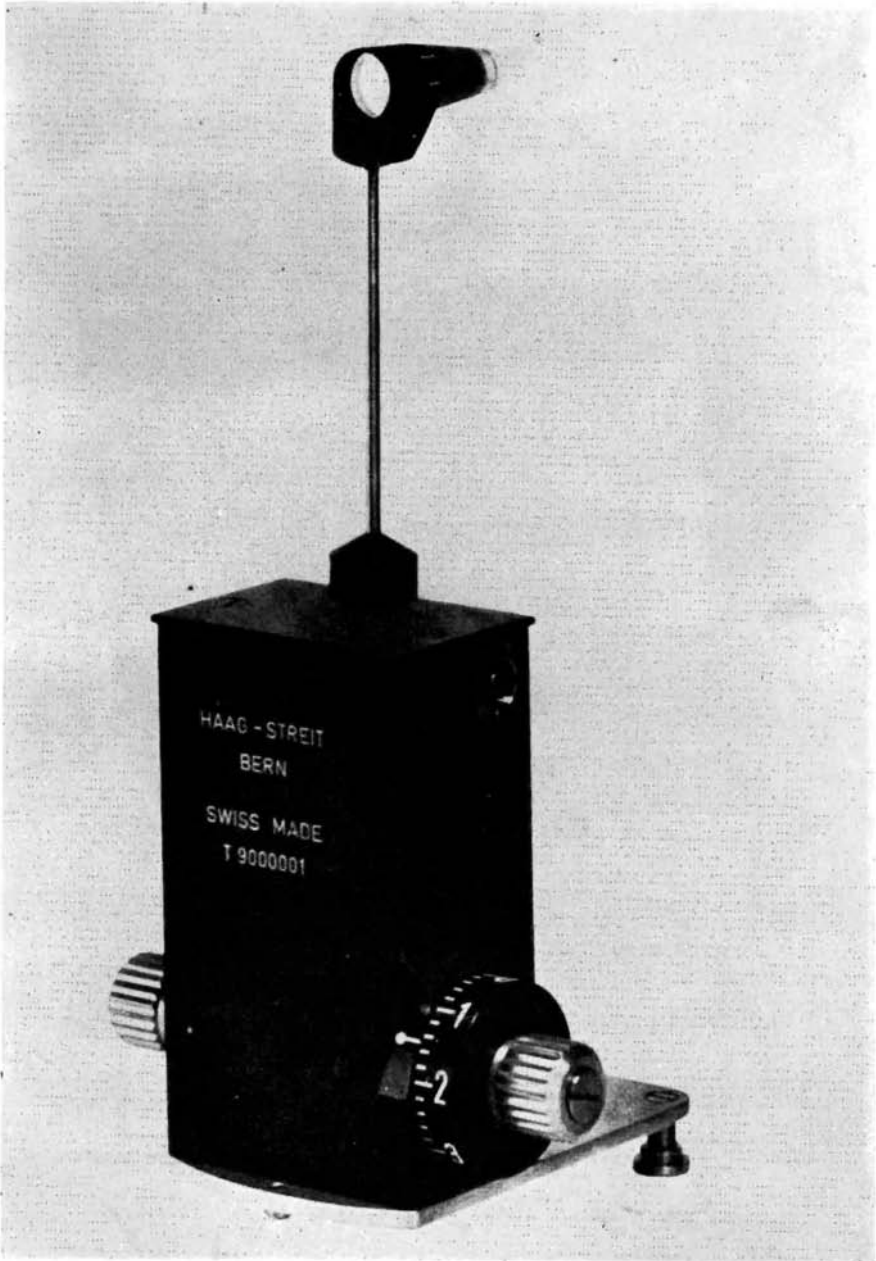

Figura 7 — Tonômetro de Maklakov modelo Filátov-Kalfa que usamos.

APLANOTONOMETRIA



Figura 8 — Onde se vê o desvio padrão usando o pêso 5 g. de Maklakov.

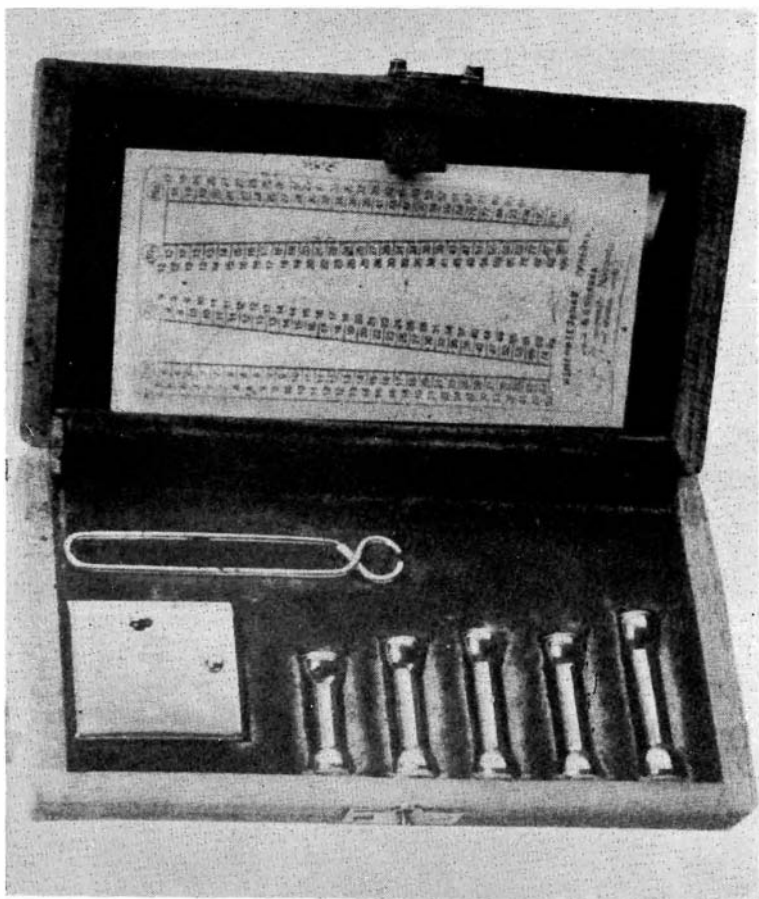

Figura 9 — Histograma comparativo entre os dois tonômetros, com o pêso 5 g. de Maklakov.

## COMENTÁRIOS

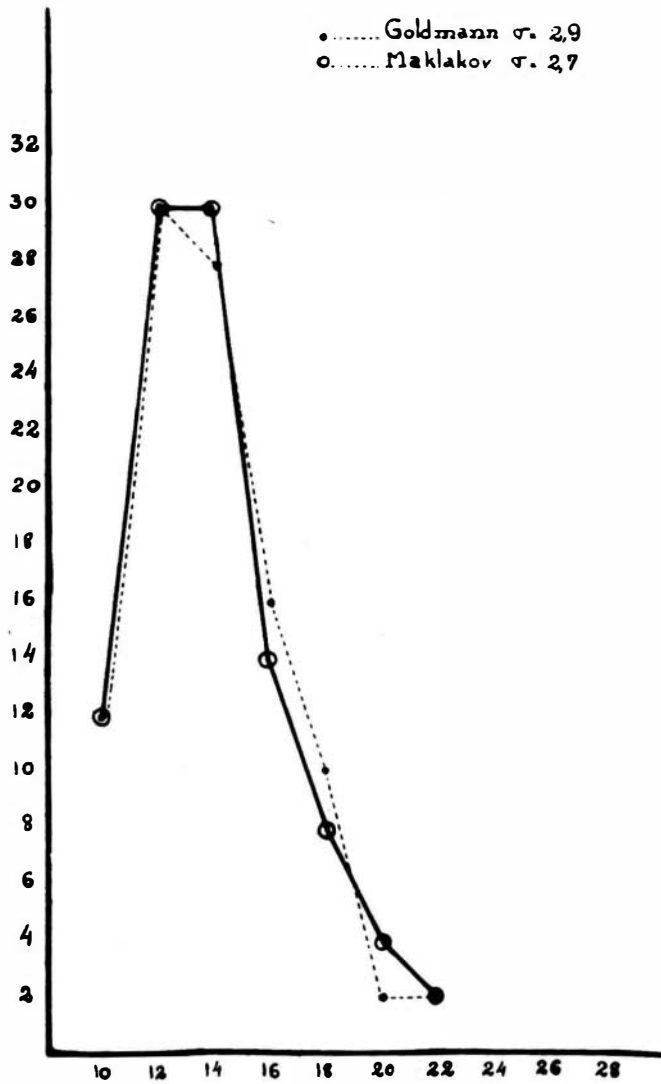
Casanova <sup>1</sup> e Quintana <sup>13 - 14</sup> encontraram resultados similares com os dois tipos de aplanotometria. Gloster e Martin <sup>5</sup> não encontraram superponibilidade dos resultados como afirmara Posner <sup>8</sup>: — “Parallel measurements made with the Goldmann tonometer have shown a surprisingly close correspondence between this and the Maklakov tonometer, at least in the borderline range, when the 5 gram tonometer is used”.

Quintana, em trabalhos sucessivos <sup>13 14 15 16 17</sup>, mostra que o tonômetro de Maklakov foge à lei de Imbert-Fick devido ao diâmetro maior da aplanção, o que, teoricamente, não ocorre com o de Goldmann. Assim enquanto com o tonômetro de Goldmann não precisamos levar em linha de conta rigidez escleral, tensão superficial da lágrima, volume mobilizado de Humor Aquoso (de 0.56 mm<sup>4</sup>) nem curvatura da córnea, sendo a Po. medida diretamente, por uma área constante de aplanção com diâmetro de 3.06, portanto dentro da faixa que permite a aplicação da Lei de Imbert-Fick, tal não acontece com o aparelho de Maklakov que tem uma área variável de aplanção e segundo Quintana está sujeito à igualdade de Friedenwald em que

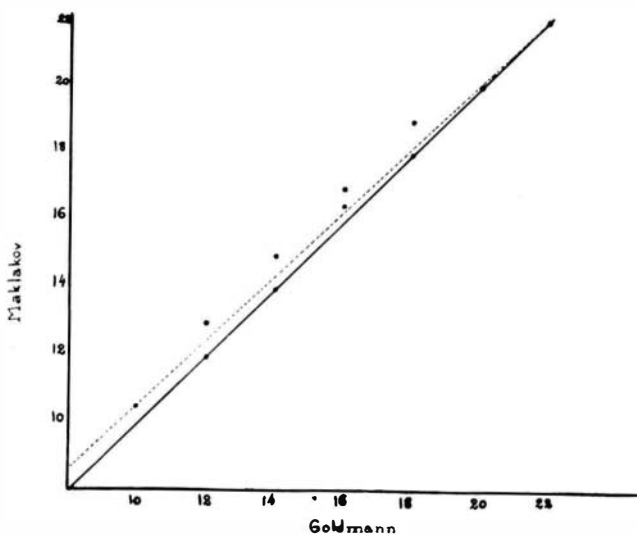
$$\text{Log. de Po é igual a Log. de Pt} - KV.$$

Exige portanto uma escala de calibração. A escala de Posner de 1962, segundo Gloster e Martin, dá superestimação dos resultados nas baixas pressões e subestimação das pressões elevadas, quando os resultados são comparados com as leituras obtidas com o Goldmann.

Quintana fez também uma escala de calibração, calculou os volumes de mobilização de aquoso com referência ao diâmetro da área aplanada e de raio de curvatura da córnea, realizou um nonograma que nos dá a Po e a rigidez escleral e os seus resultados são muito próximos dos fornecidos pelo método de Goldmann.

Posner e Inglima já nos prometem nova escala de calibração para corrigir a superavaliação que ocorre com o Maklakov ao redor de 10 a 17 mmHg. e subavaliação ao redor de 30 a 38 mmHg.

Trabalho de T. Schwartz, realizado êste ano, comparando o aplanômetro de Posner-Inglima, Goldmann e Schiötz, ainda não publicado, mostrou resultados iguais com os 2 métodos de aplanção, usando a nova escala de Posner-Inglima. A pesquisa foi feita em larga escala no Arizona e revelou iguais resultados entre Goldmann e Maklakov acima de 17 mmHg. e leituras sempre mais baixas com o Schiötz.

Os nossos resultados mostraram grande aproximação com o pêso 5 g. revelando uma média de 13.92 mmHg. para com o Goldmann e 14.21 com o Maklakov e pêso 5 g. o que traduz uma diferença de 0.29 em 100 olhos normais examinados. Já com os pesos 7.5 e 10 g. obtivemos leituras maiores, respectivamente 15,20 e 16,62 o que traduz uma diferença entre Goldmann e Maklakov de 1.28 e 2.70 para os dois pesos assinalados.

Os resultados por nós obtidos autorizam o uso do pêso 5 g. na pesquisa de olhos glaucomatosos dentro dos aparentemente normais. Tivemos resultados concordantes com os de Posner <sup>8</sup>.

Deve ser feita uma larga comparação entre os dois métodos de aplanção abrangendo tôdas as faixas, normais, suspeitos e glaucomatosos.

#### *Vantagens assinaladas do método de Maklakov*

Posner-Inglima <sup>11</sup>, Casanovas <sup>1</sup>, Gloster e Martin <sup>5</sup>, são unânime em afirmar a simplicidade do instrumento, sem mecanismo sujeitos a desregulamentos, exigindo calibrações, além da facilidade de manuseio, o que res possam tomar as impressões das áreas aplanadas, facilitando o estudo das curvas nicteméticas, sem a hospitalização do paciente, que pode ficar na sua própria casa.

Scott Heat <sup>6</sup> em visita à URSS e analisando a oftalmologia soviética faz a seguinte referência ao tonômetro de Maklakov: — “The chief advantages of the Maklakov tonometer are: a) readings for a given patient are standard under all climatic conditions; b) readings for a given patient are the same whether tonometry is done by a nurse in Irkutsk or a doctor in Moscow; that is, readings are not as subject to errors in reading and recording, as on a Schiötz tonometer; c) readings in 1964 and 1984 will be the same, or almost the same; d) instrument does not break and cannot go out of adjustment; e) errors due to ocular rigidity are minimal; f) instrument is easy to clean and sterilize”.

A respeito dos seus resultados assim se expressa Scott Heat <sup>6</sup>: “My measurements with the Maklakov tonometer varied no more than 0.1 to 0.2 just as predicted and as Kalfa (1936) reported”.

Os nossos resultados, obtidos com o pêso 5 g. deram uma diferença de 0.29

## CONCLUSOES

- 1 — Os nossos resultados em 100 normais olhos examinados revelam que o pêso 5 g. deu uma diferença entre o Goldmann e o Maklakov de 0.29 mmHg.
- 2 — As médias de Po nos 100 olhos examinados deram as seguintes leituras:  
Goldmann 13.92 mmHg.  
Maklakov 14.21 com pêso 5 g.  
15.20 com pêso 7.5 g.  
16.62 com pêso 10 g.
- 3 — Praticamente nossos resultados concordam com Posner <sup>8</sup>, Heat <sup>6</sup>, Quintana <sup>17</sup> e Casanovas <sup>1</sup>.
- 4 — Usamos a escala de calibração de Posner (1962).
- 5 — Uma larga investigação deve ser feita abrangendo tôdas as faixas: olhos aparentemente normais, suspeitos de glaucoma e glaucomotosos para melhor se poder aferir os resultados de ambos os métodos.
- 6 — Os resultados obtidos aliados à simplicidade e baixo custo do tonômetro de Maklakov são um incentivo para o seu uso mais generalizado.

## SUMÁRIO

A autora faz o estudo comparativo entre os resultados obtidos nas leituras de 100 olhos, *aparentemente normais e com visão de 20/20*, com os tonômetros de Goldmann (montado na lâmpada de fenda Haag Streit 900) e o tonômetro de Maklakov, versão Filátov-Kalfa.

As médias obtidas com o tonômetro de *Goldmann* (13.92 mmHg.) e com o tonômetro de *Maklakov* *pêso 5 gramas* (14.21 mmHg.) revelaram uma *diferença de 0.29 mmHg.* Praticamente as médias são superponíveis, já que a diferença encontrada é inferior ao erro aceitável de 0.50 mmHg. para o tonômetro de Goldmann. O confronto dos resultados entre os dois tonômetros com os pesos 7.5 e 10 gramas mostraram diferenças sensíveis para olhos normais. Assim com o *pêso 7.5* a média foi de 15.20 mmHg. e com o *pêso 10* foi de 16.62 mmHg. o que dá respectivamente uma diferença com o tonômetro de Goldmann de 1.28 mmHg. e 2.70 mmHg.

O levantamento estatístico entre as leituras com os dois tonômetros mostrou grandes divergências com os pesos 7.5 e 10 gramas. As leituras do tonômetro de Maklakov com o *pêso 5 gramas* são perfeitamente superponíveis com uma diferença entre as médias obtidas com os 2 instrumentos de apenas 0.29 e um desvio padrão de 2.7 para o tonômetro de Maklakov e 2.9 para o tonômetro de Goldmann sendo a área de dispersão menos ampla com o tonômetro de Maklakov. A curva de Gaus praticamente superponível e o histograma revela maior coincidência entre as leituras a partir de 12 mmHg.

## SUMMARY

A comparative study of the results of tonometric readings of 100 apparently normal eyes with 20/20 vision was made. The readings were obtained with the Goldmann tonometer mounted on a Haag-Streit Slit-Lamp 900 and the Maklakov tonometer, model Filatov-Kalfa. The mean value of the readings obtained with Goldmann's tonometer was 13.92 mm Hg whereas the mean value with Maklakov's tonometer (weight 5 gr) was 14.21 mm Hg. which gives a difference of 0.29 mmHg a value inferior to the permissible error of 0.50 mm Hg for the Goldmann tonometer.

A comparison of these results with those obtained by using 7.5 and 10.0 gr showed significant differences for normal eyes. Thus, with a weight of 7.5 gr. the mean value was 15.20 mmHg and with a weight of 10.0 gr the mean

value was 16.62 mmHg, in this way presenting respectively differences of 1.28 mmHg abd 2.70 mmHg against the Goldmann tonometer.

The statistic comparison of the readings given by the two tonometers Goldmann's tonometer and Maklakov's tonometer (weight 5 gr) and these with the weights of 7.5 and 10.0 gr. showed marked difference. The readings with the Goldmann tonometer abd with the Maklakov tonometer (weight 5 gr.) are in perfect agreement with a difference of only 0.29 mmHg and standart deviation of 2.7 for Maklakov tonometer and 2.9 for Goldmann's tonometer, the distribution area for the former being less broad. The Gaussian curves are in good accordance and the histogram show better agreement between the readings above 12 mm Hg.

#### BIBLIOGRAFIA

- 1—CASSANOVAS (J.), QUINTANA M. e MENEZO (J. L.). La tonometria de aplanación según el método de Maklakov y sus derivados. Arq. Port. Oft. 1963 fasc. 1:5/17 Lisboa.
- 2—CALIXTO (N.). Tonometria - in Glaucoma, Edicos Procoewe Paiva Gonçalves 1966. Rio.
- 3—DUKE-ELDER (S.). Tonometry in the Foundations of Ophthalmology. Vol. 11, 336/355 Krimpton-London 1962.
- 4—FILATOV (V. E.). El Glaucoma y su tratamiento en mi camino en la ciencia (URSS-Moscú), 1957: pg. 109/141.
- 5—GLOSTER E MARTIN. Evaluation of the Posner-Inglima applanometer Brit. J. Ophth 1965, VI. 49: 12/617/625, London.
- 6—HEAT (SCOTT-. Soviet Ophthalmology Am. J. Opht. 1965, Vol. 59 N° 1: 69/88.
- 7—OURGAUD e ETIENNE. L'exploration foncionelle de l'oeil glaucomateux 1961. Masson, Paris.
- 8—POSNER (A.). An evaluation of Maklakov applanation tonometer in Eye, Ear, Nose, Thr. 1962. (May). 41:377/378.
- 9—POSNER (A.). Modified conversion tables for Maklakov tonometer iden (1962-, 41:638/644.
- 10—POSNER (A.). Methods used in the recalibration of the Maklakov tonometer iden (1962), 51:1028/1029.
- 11—POSNER-INGLINA. Clinical aspects of applanometry. Annual meeting of Am. Acd. of Ophth & Otolaring. Chicago, 1965, Nov. 14-19.
- 12—ROCHA (HILTON) —e Calixto (Nasim). Considerações sôbre Tonografia. Arq. Brs. Oft. Vol. 22, n° 6, 1959: 301/354.
- 13—QUINTANA (MANUEL). Perfeccionamientos en la tonometria de Maklakov, 1964. Arch. S. Of H. A., tomo XXIV, n° 10.
- 14—QUINTANA (MANUEL). Tonometria con el tonómetro de Maklakov. Arch. S. O. H. A. Tomo XXV, n° 6, 1965.
- 15—QUINTANA (MANUEL). Utilización de la igualdad de Friedenwald con el tonómetro de Maklakov. Nomograma Arch. S. O. H. A. 1965, tomo XXV, n° 5.
- 16—QUINTANA (MANUEL) Curvas Elastométricas. Arch. S. O. H. A. 1965. Tomo XXV, n° 5.
- 17—QUINTANA (MANUEL). La relación Presión-Peso en tonometria. Rv. Bras. Oft. VI. XXV, n° 1. (Março), 1965: 5/15.

P. O. Box 440.  
Goiânia - E. de Goiás

## UN CASO DE PARALISIS NUCLEAR DEL -III- PAR

POR

PEDRO A. GUIDO B., M.D.

Santa Marta - Colombia.

*Anamnesis:* Paciente de 64 años de edad, que acude a la consulta porque una semana antes del examen se instauró súbitamente, vértigo objetivo y subjetivo sin componente neurovegetativo, con cefalea parietal derecha, diplopia.

La paciente venía siendo tratada por amibiasis, diabetes, obesidad, hipertensión arterial, con: acetazolamida tabletas 250 mgrs. 2 por semana, dieta de 1.300 calorías, gondafon, eritromicina tabletas 60 1c/6 horas.

*Examen:* Se trata de una paciente en perfecto ptosis palpebral superior derecha moderada, estrabismo divergente de O. D. en PPM, diplopia a veces, tortícolis compensatorio. En posición extrema de mirada a la izquierda es ostensible la parálisis de RMD.

*Biomicroscopia:* Polo anterior normal.

*Agudeza Visual*

V. D. : 0.2 + 2.5 : 0.8 + 5.5 N° 1

V. I. : 0.1 + 2.5 : 0.8 + 5.5 N° 1 C.N

*Campo Visual:* Ver esquema.

*Oftalmoscopia*

Papila normal A.O.

Vasos algo adelgazados de calibre

Signos de Sallus-Gunn grado II

Drusas perimaculares en O.I.



*Tonometría*

<u>6</u>	<u>11</u>	<u>6</u>
5.5	10	5.5
Po: 16	E: 0.19	Po: 16

*Test de Diplopia*

Se establece el siguiente plan:

- estudio de condiciones sensoriales
- estudio de condiciones motoras
- fotografía en diferente posición de mirada
- examen neurológico
- exámenes de laboratorio
- examen ORL
- tratamiento

Historia de  
Estrabismo

*Examen Neurológico*

Se trata de paciente ligeramente obesa de 64 años de edad, bien orientada en tiempo y espacio. Estado nutricional y de desarrollo normal. Tensión arterial: 160 x 80. Pulso 80, regular. A excepción de la parálisis parcial del III par (RMD y elevador del párpado superior de O.D.), la exploración neurológica fue normal.

*Exámenes de Laboratorio*

LCR: R. cardioplipina (VDRL) positiva  
 R. Pandy: negativa  
 Proteínas totales: 40 mgrs% (18-35 mgrs%)  
 Glucosa 150 mgrs% (40-70 mgrs%)  
 Cloruros (Na Cl) 870 mgrs% (690-760 mgrs%)  
 Número de células por CC : 5  
 R. Hanger : Positivo  
 En sangre : R. cardioplipina negativo, mazzini y Kahn negativo  
 GR: 4'480.000 Hb : 12,45 gr. Leucocitos 6.800 Eosinofilos : 9  
 Resto normal.  
 Neutrofilia relativa, eosinofilia absoluta y relativa.  
 Proteinemia  
 Proteínas totales 7.10 gr%  
 Albúminas 5.10 gr%  
 Globulina 2 g.  
 Relación A/G 2.55  
 Creatininemia : 2 mg.

*Examen Oral:*

Rinoscopia anterior y posterior, orofaringe, laringoscopia indirecta, otoscopia, exploración senos paranasales, pruebas vestibulares y cocleares normales. Audiometria tonal: déficit conducción ósea y especialmente aérea (presbiacusia, otosclerosis).

*Diagnóstico:*

Parálisis parcial nuclear del III par: elevador del párpado superior O.D. y de RMD. Diabetes. Hipertensión arterial. Obesidad.

*Tratamiento:*

Penicilino-terapia. Antihipertensivos. Hipoglicemiantes.

*Discusión.*

Este caso se ha considerado como parálisis parcial nuclear del III par y en gracia de discusión vamos a recordar que las parálisis del III par son parciales o completas y que en un recuento topográfico las lesiones que podemos encontrar se clasifican con Alfred Huber de la Universidad de Zurich como sigue:

*Parálisis del III Par.*

Los signos característicos de disturbio de la motilidad incluyen en el cuadro completamente desarrollado: ptosis, parálisis del RS, del RM, del RI, y del OI, además midriasis con una respuesta perezosa a la luz y a la convergencia. En la PPM. el ojo afectado se desvia hacia abajo y hacia afuera. Hay una diplopia horizontal y vertical en PPM. La diplopia vertical aumenta con la elevación y depresión. La diplopia horizontal aumenta con la rotación hacia el lado del ojo afectado.

*Clasificación.*

1) *Formas Nucleares.*

Parálisis de uno o de unos pocos músculos extraoculares inervados por el III par en uno o en ambos ojos. Puede o no haber disturbios pupilares (midriasis, reflejo fotomotor perezoso) o parálisis de la acomodación. En los tumores cerca del mesencéfalo (pinealoma), hay una combinación de parálisis musculares aisladas con parálisis conjugadas vertical, posiblemente una alteración de la convergencia y nistagmus retractoria. (Síndrome de Parinaud, Síndrome del acueducto de Silvio y Síndrome pineal).

2) *Formas Fasciculares.*

*Tipo Dorsal* Paresia oculomotor unilateral con hemitemblor cruzado (Síndrome de Benedict), posiblemente con hemianestesia cruzada.

*Tipo ventral* Paresia del III par completa casi siempre unilateral con hemiplejía cruzada (Síndrome de Weber), posiblemente con parálisis del hipogloso y facial central cruzadas.

3) *Tipo radicular* Paresia del III par unilateral con hemiplejía cruzada (Síndrome de Weber).

4) *Formas Basales*

Una lesión localizada que muestra una parálisis oculomotora monosintomática con afecciones variadas del esfínter pupilar y del músculo ciliar (aneurisma de la arteria comunicante posterior o mejor aneurisma en el sitio de separación de la comunicante posterior con la arteria carótida interna).

Una lesión difusa y grande localizada en la base del cráneo (tumores, meningitis basal), están caracterizadas además por lesiones del IV, V, VI y posiblemente VII y VIII pares.

*Síndrome del Seno Cavernoso.*

Paresia del III par unilateral (casi siempre con pereza absoluta o rigidez pupilar) combinadas con paresia de IV - V - VI. (tumores especialmente en el seno cavernoso, adenomas pituitarios con expansión lateral, meningiomas de la fosa media, neurinomas del trigémino). *Forma posterior.* Lesiones de la 1ª 2ª y a veces 3ª rama del trigémino. La forma anterior por lesiones de la 1ª rama del trigémino.

*Síndrome de la Fisura Orbital Superior.*

Parálisis III par unilateral, asociada con paresia del V (1ª rama) y del VI, ausencia del signo del seno.

*Síndrome del Apex.*

Paresia del III - IV - V primera rama y del VI, combinados con lesiones del nervio óptico, (escotoma central, defectos periféricos de los campos visuales, posiblemente papiledema). Exoftalmo en caso de tumores.

En vista de lo anteriormente transcrito se considera que el caso que se presenta es parálisis del tipo nuclear.

Se recuerda que los núcleos del III par están constituídos por dos grupos uno formado por células grandes localizadas hacia la línea media de los pedúnculos cerebrales, cerca al acueducto de Silvio, a nivel del tubérculo cuadrigémino ante-

rior y que da origen a las fibras que inervan todos los músculos estriados de la órbita excepto dos. El núcleo de Perlia se encuentra hacia el centro del grupo de células grandes.

El segundo grupo de células pequeñas, situado hacia la porción tostral del grupo de células grandes constituye el núcleo de Edinger-Westphal que da origen probablemente a la inervación del iris y del cuerpo ciliar.

*Diagnóstico Diferencial.*

- 1) Aneurismas del polígono de Willis (de la comunicante posterior o del sitio de la unión de la comunicante posterior con la carótida interna).
- 2) Sífilis vascular del mesencéfalo.
- 3) Polioencefalitis hemorrágica aguda anterior (Wernicke).
- 4) Esclerosis múltiple.
- 5) Encefalitis letárgica (Von Economo).
- 6) Diabetes Melitus.
- 7) Tumor intracraneano (lóbulo temporal con herniación en el tentorio).
- 8) Estados iniciales de la parálisis general.
- 9) Miastenia gravis.
- 10) Oftalmoplejía por carencias y toxinas: envenenamiento por plomo, botulismo, difteria, influenza.
- 11) Tumores de la hipófisis, del mesencéfalo y de los tubérculos cuadrigéminos, pinealomas y de los pedúnculos cerebrales.

*Conclusión.*

Se relata la historia de paciente que mejoró de parálisis parcial de III par inicialmente diagnosticado de aneurisma del polígono de Willis, de la comunicante posterior derecha con infiltraciones ligeras del aneurisma. Al hacer la punción lumbar se encontró un LCR cristalino que fue reportado con VDRL positivo, deduciéndose que se trataba de parálisis parcial nuclear del III par por sífilis vascular del mesencéfalo.

No es frecuente pero hemos tenido varios casos similares, por lo cual antes de hacer tratamiento quirúrgico deben agotarse las posibilidades etiológicas.

PEDRO A. GUIDO B.

*BIBLIOGRAFIA*

- A. FRANCESCHETTI y J. BLUM, *Oftalmología Amsler-Brückner*, Franceschetti Goldmann. Salvat Editores S. A. pp. 548, 1954.
- ALFONSO CASTANERA PUEYO, *Estrabismo*. Editorial Paz Montalvo. Madrid, pp. 61, 1952.
- ALFRED HUBER, *Eye symptoms in brain tumors*. The C. V. Mosby Company. St. Louis, pp. 47, 55-56, 1961
- DUKE-ELDER, *Enfermedades de los ojos*. Interamericana S. A. México, pp. 484-485, 1965. Staff in Neurology of the Mayo Clinic, *Clinical Examinations in neurology*. W. B. Saunders Philadelphia, pp. 78-80, 1957.

## A CLINICAL CORRELATION BETWEEN FOCAL INFECTION AND EYE DISEASES

BY

MULHIM A. N. HASSAN, M.D.

Beirut, Lebanon

In the 1959 and 1960 Annual Meetings of the International Association for Dental Research two papers only were on focal infection out of 611 papers; while in the 1966 International Congress of Ophthalmology in Munich not a single paper was on focal infection.

This reveals that the focal infection theory has lost its influence and is no more considered a source for many systemic manifestations as it was in the first decades of the century.

Yet the theory was not completely neglected. Many cases that benefited after extraction of an infected tooth, excision of an infected tonsil or treatment of an infected sinus or ear are still constantly being reported in the literature.

Since long time the etiology of iritis, uveitis and optic neuritis was correlated with focal infection in general and dental infection in particular. No reason was given why other parts of the eye are immune against these foci of infection.

To evaluate and confirm the well established relation of focal infection to iritis, uveitis and optic neuritis; and to study if there is a relation between focal infection and other diseases of the eye; a clinical research was started in my clinic few years ago.

In order to be able to make an accurate correlation, a definite, consistent and well controlled technique was used in the examination and follow up of all cases reported.

A strong light and a magnifying loop were used in the investigation. Pyorrhetic teeth, with pus and/or blood coming out spontaneously, or by pressure on the

gum; caried teeth, stuffed or non-stuffed, that have lost their nerve, pulp and color; peeping out wisdom teeth with infected pockets or operculums; inflamed palate due to a bad denture, with or without sucking cups or grooves were all considered potential foci of infection that should be removed, if they could not be treated and cured. Roots, apical abscesses, granulomas and fistulas, and infected big tonsils were considered as foci of infection and should be treated by removal of the roots or teeth and treatment or excision of the tonsils. Sinusitis was discovered by feeling of tenderness in the region of all the sinuses. Any suspicion was confirmed by X-ray. Otitis media was easily diagnosed. Treatment of infected teeth, sinusitis and otitis media were trusted to the specialist. Rarely was the focus of infection outside the orifices of the head.

Once this survey for foci of infection was over, a thorough study of the eye manifestations or diseases was started with all the modern means of diagnosis available. Then the results were correlated with the pathogenic foci of infection and reported.

### *Report of Example Cases*

#### *A. Chalazion*

J. A. K., A 30-year-old woman, was seen April 1, 1966, with two chalazions in the left lower lid. She stated that these chalazions were formed just after extraction of a left upper infected molar and subsequent inflammation of the gum.

#### *B. Spring Catarrh*

T. S. T., an 11-year-old girl, was seen June 1, 1966, with huge catarrhal follicles in both upper lids and advanced invasion of both corneas, reaching very near to pupillary region, of 7 years duration. Photophobia lacrimation and redness were excessive. Previous treatment with cortisone drops did not improve much the condition and the catarrh was getting worse every day. The left eye was more affected. She had big infected tonsils (the left one bigger), red, edematous and inflamed gum around peeping out permanent teeth and some infected pyorrhetic teeth in the lower jaw. Surgical excision of the follicles in the lids followed by local treatment with 2% Silver nitrate, prednisolone drops, and systemic treatment of the infection of the tonsils and teeth with Denkamycin injections, im, and Kenacort tabs., p. o., improved the condition considerably; less tearing and photophobia, and clearing of corneas.

Suddenly a right lower molar got infected and an acute apical abscess was formed that extended to the cheek. An acute keratoconjunctivitis was formed immediately in the right eye (the better eye) only, with increased photophobia and

lacrimation. The left eye remained quiet. The right eye quieted down after extraction and treatment of the infected molar.

After a short period of increasing improvement the catarrh recurred in both eyes. The cause was, this time, an acute inflammation of both tonsils. Excision of the tonsils was recommended, otherwise systemic treatment with antibiotics, sulfa and corticosteroids should be repeated. The patient was not seen again.

### C. *Lachimal Apparatus*

E. A. T. Z., a 30-year-old woman, was seen April 16, 1966, with obstruction of the left lacrimal duct. She had an apical abcess of a left upper incisor on the same side, the rest of the teeth being normal.

2. A. A. K., a 35-year-old man, was seen May 5, 1966, with stenosis of the left lacrimal duct and swelling of the sac. He had an apical abcess of the left upper canine on the same side, the rest of the teeth being normal.

### D. *Conjunctivitis*

N. M. S., a 4-year-old girl, was seen October 19, 1966, with an acute purulent conjunctivitis in the right eye only; the left eye was normal. An acute apical abcess, with pus and blood coming out, of a right upper premolar on the same side was found; the rest of the teeth and the left eye were normal.

### E. *Pterygium*

A. A. D., a 75-year-old man, was seen September 14, 1966, with a huge subconjunctival hemorrhage and a huge pterygium in the right eye only. The left eye had a mild conjunctivitis — episcleritis. He had an infected root of a right upper premolar on the same side; the rest of the teeth in the upper jaw were out; the lower jaw had no teeth left except the lower incisors, that were degenerated and infected.

### F. *Corneal Ulcers*

1. M. Y. A., a 38-year-old man, was seen September 9, 1953, with a dendritic ulcer in the left eye. The ulcer recurred May 2, 1955 and March 16, 1957, when it was discovered that the ulcer came after infection of a left lower molar and the left tonsil. The molar was removed and the tonsil treated. The ulcer did not recur since then.

2. A. A. F., a 52-year-old man, was seen May 6, 1960, with a recurrent dendritic ulcer and keratitis decemetitis of long duration. The ulcer and keratitis recurred many times in each of the years 1961, 62, 63, 64 and 65. After extrac-



tion of all the pyorrhetic infected teeth on the left side the ulcer did not recur until February 6, 1967 (after 1 year and 5 months), when he was exposed to hard work, bright sun and high wind. The remaining left upper canine and lateral incisor were found infected, the wind and fatigue in the sun were precipitating factors.

3. M. H. S., a 42-year-old woman, was seen March 20, 1961, with a wide ulcer in the cornea of the right eye, which was treated and cured. The ulcer recurred only January 13, 1966, immediately after extraction of a right upper infected molar and inflammation of the gum following the extraction.

### *G. Subconjunctival Hemorrhage*

S. I. D., a 52-year-old teacher, was seen February 19, 1965, with a huge subconjunctival hemorrhage in the left eye. An infected pyorrhetic left upper molar on the same side was found. Four months later he had an acute apical abscess of a right upper molar that extended to the right cheek. Immediately after the abscess another subconjunctival hemorrhage was formed in the right eye on the same side. The hemorrhage began to get absorbed as the abscess began to clear.

### *H. Iritis*

J. O. V., a 52-year-old man, was seen April 2, 1954, with a new attack of a recurrent iritis in the left eye, which was treated and controlled. He had advanced pyorrhea in all his teeth and chronic otitis media, (after an accident), in the left ear since 1927. September 22, 1954, he had a new attack of iritis and hemorrhage in the left eye, which could be well controlled by antibiotics, corticosteroids and fever therapy. April 17, 1958, he had another attack of iritis and secondary glaucoma in both eyes. March 20, 1959, he had an attack of glaucoma only in both eyes. The iritis and glaucoma were well controlled and did not recur since then. The otitis media in the left ear cleared also and did not recur. The cure of the eyes and ear was complete after total extraction of the pyorrhetic teeth and local and systemic treatment of the eye and ear manifestations by antibiotics, sulfa, corticosteroids and fever therapy.

### *I. Glaucoma*

1. M. S. A., a 37-year-old man, was seen February 25, 1965, with chronic simple glaucoma in both eyes. All his teeth had advanced pyorrhea. With the glaucoma treatment (pilocarpine and diamox), all the teeth on the right side only, in both jaws, from midline to the right were extracted. March 2, 1965, the tension in the right eye fell 10 mm Hg, while in the left eye it fell only 5mm Hg. Vision in the right eye improved 5ft. and in the left eye only 2ft. Patient was asked to remove his teeth on the left side. Patient did not return.

2. K. Y. H., a 75-year-old woman, was seen March 28, 1966, with chronic simple glaucoma in both eyes. All her teeth were pyorrhetic. She was asked to remove all her teeth, but she removed the teeth on the right side only. April 2, 1966, tension fell 5mm Hg in the right eye and 0-1mm Hg in the left eye; the glaucoma treatment was the same for both eyes. Antibiotics were used also.

*J. Cataract*

1. H. Y. H., a 60-year-old man, had iridencleisis for glaucoma in both eyes November 25, 1963. Vision after surgery was  $6/18 \pm$  in the right eye, and  $6/9 \pm$  in the left eye. His teeth were all pyorrhetic. He was asked to remove them all. October 22, 1964, vision in the right eye was still  $6/18 \pm$ , but was counting fingers at 18ft. in the left eye. The left eye had a developing cataract and signs of previous mild iritis. All the teeth have been removed, leaving a root in the left upper jaw on the same side of the iritis and cataract newly formed.

2. M. Z. I., an 80-year-old man, had a cataract extraction in the right eye April 22, 1965. The left eye had a posterior capsular and central lens change. Vision in the left eye was  $6/36 \pm$ . His teeth in the upper jaw were all out except for a root and two infected molars on the left side. June 18, 1965, vision in the left eye improved to  $6/9 \pm$  after extraction of the remaining root and two infected molars in the upper jaw on the left side, and the use of antibiotics and corticosteroids.

3. K. I. C., a 55-year-old woman, was operated for glaucoma in the left eye February 8, 1958. The right eye was blind with absolute glaucoma. She had an immature cataract in the operated eye. Vision was finger-counting at 6-8ft. after surgery. Vision remained the same in check-ups of 1959 to 1961. Seen September 28, 1965, her vision improved to  $6/36 \pm 1$ . This improvement came 7 years after surgery for glaucoma, although the cataract was still present. The improvement came after extraction of a right upper infected premolar.

4. K. G. B., an 8-year-old boy, was seen February 26, 1965, with a posterior polar and central lens change in the left eye. The eye received a mild blow a year ago. Vision was 6/6 in the right eye and counting fingers at 20 cm. in the left eye. Treatment of an abscess in the left lower first premolar (by antibiotics and corticosteroids), and extraction of a degenerated, caried, infected milk tooth riding over the peeping out tooth implanted in the infected gum, improved vision in the cataractous eye from counting fingers at 20 cm. to  $6/36 \pm$  in 12 days. The cataract began to clear partly and fundus was better seen. Later vision failed again to finger-counting at 10ft. because his father stopped systemic treatment with antibiotics and corticosteroids, insisted on surgery, refused to continue treatment and disappeared.

*K. Retinal Detachment*

1. M. S. D., a 51-year-old man, was seen November 20, 1961, with a detachment of the retina in the lateral quadrant, at 3 o'clock, of the left eye, of one day duration. Vision was  $6/36 \pm 2$  in the right eye and finger-counting at 4-5ft. in the left eye. A beginning of lens changes was noticed in both eyes. Absolute bed rest, bandaging both eyes, cortone and atropine drops locally, antibiotics and corticosteroids systemically, and extraction of all the pyorrhetic teeth on the left side, reattached the retina in 28 days and vision improved to  $6/12+$  (with correction).

2. H. A. H., a 25-year-old woman, was seen March 27, 1963, with detachment of the retina in the left eye from 4-8 o'clock. Tension was soft. Vision was finger-counting at 20cm. Extraction of a left upper infected wisdom tooth; irregular bed rest; systemic treatment with antibiotics and corticosteroids; local treatment with atropine and cortone drops, reattached the retina partly in 3 months and completely in 6 months. Vision improved to finger-counting at 18ft., without correction. March 23, 1966, the retina was still attached and vision was the same.

3. M.M.K., an 8-year-old boy, was seen September 26, 1966, with a detachment of the retina in the lower quadrant of the left eye and a big hole at 6 o'clock. Tension was 38 Schiotz and flare was positive (++) in the anterior chamber. Vision was 6/6 in the right eye and light perception, no direction in the left eye. Bed rest and bandaging both eyes, treatment of an abcess of a left lower premolar; and extraction of a riding, degenerated and infected decayed milk tooth; local treatment by cortone and pilocarpine drops; and systemic treatment by antibiotics, corticosteroids and diamox improved vision to finger counting at 4-5 meters in 33 days. The retina was reattaching and clearing. The right eye was normal and the rest of his teeth were normal. The patient disappeared for no known reason.

*L. Retinitis*

1. A.S., Abou Gh., a 16-year-old boy, was seen March 4, 1966, complaining of failing vision in both eyes. His vision was  $6/60+1$  in both eyes. He had otitis media chronica since young. His teeth, tonsils and sinuses were apparently normal. The macular regions in both eyes were covered by white scar-like streaks and the foveas were not well demarcated. Treatment of the otitis media locally and systemically by antibiotics and corticosteroids, improved his vision to  $6/18+$  (without correction) in both eyes, and the maculas cleared, in 11 days.

2. N.M.H., a 55-year-old man, was seen April 19, 1964, with hemorrhage in the right macula. All his teeth were removed except the right upper canine and

first premolar, which were highly infected and their infection has extended to the neighbouring maxillary sinus. Both tonsils and ears were normal. The hemorrhage was on the side of the infected teeth and sinus. The other eye was normal.

*M. Optic Neuritis*

N.A.M., a 49-year-old woman, was seen November 2, 1965, with optic atrophy in the right eye. Vision was 6/6 in the left eye and finger-counting 3-4ft. in the right eye. Vision improved to finger-counting at 18ft. with antibiotic and corticosteroid treatment. But vision improved to 6/9±+++ from side, May 21, 1966, after she had completed the extraction of 6 highly infected teeth on the same side, and the same treatment with antibiotics, corticosteroids and fever therapy.

*Discussion and Conclusion*

“Case histories of patients receiving distinct benefit from elimination of foci of infection are constantly being reported in medical and dental literature. Included are conditions such as subacute bacterial endocarditis <sup>1</sup>, torticollis <sup>2</sup>, menieres syndrome <sup>3</sup>, glaucoma <sup>4</sup>, infectious diseases of the eye including uveitis <sup>5</sup>, <sup>6</sup>, iridocyclitis, tenonitis, episcleritis and optic neuritis <sup>7</sup>, dermatitis <sup>8</sup>, arthritis <sup>9</sup>, rheumatic fever <sup>10</sup>, and bacterial allergy <sup>11</sup>, <sup>12</sup>, <sup>13</sup>”.

In spite of the cases quoted above by Oartel <sup>14</sup>, those I have reported and many others on record, we find that the focal infection theory is given no attention in common practice. The reasons quoted by Grossman <sup>15</sup> to discredit the theory were the following:

1. “Many patients with diseases presumably caused by foci of infection have not been relieved of their symptoms by removal of the foci”.

Comment: This statement is wrong for the following reasons: (a) According to Cecil and Angevine <sup>16</sup>, removal of the tonsils gave a relief in 93% of rheumatic cases, because the microbes, viruses or toxins were removed with the tonsils, and no microbes, viruses or toxins were thrown during or after surgery into the circulation. (b) Removal of an infected tooth may give a relief or an exacerbation, depending on (1) the degree of infection of the tooth and the gum before and after extraction; (2) the amount of microbes, viruses, and toxins that go to the circulation during and after extraction; (3) the degree of irritation of the neuro-vegetative system during and after extraction until the gum heals. (c) The microbes, viruses or toxins that go to the circulation during or after extraction, or have already been established in a secondary focus, continue their effect on the organ they have invaded, and this focus may act as a primary

focus. These microbes, viruses or toxins should be destroyed by antibiotics, corticosteroids and fever therapy so that the organ affected goes back to normal.

2. "Many patients with these same systemic diseases have no evident focus of infection".

Comment: Arnett and Ennis <sup>17</sup>, and many other authors, considered roentgenologic examination of the teeth and the absence or presense of an apical abcess, the basis or criterium for the correlation between dental foci and rheumatism or heart disease.

This criterium adopted by Arnett, Ennis and many if not all previous authors was wrong for the following reasons. (a) Not all apical abcesses show on X-ray. (b) Apical abcesses, which can be easily seen with the naked eye and need no X-ray, make a small percentage of dental foci. Roots, advanced pyorrhea, apical fistulas and granulomas, pockets of infection or operculums over peeping out teeth, especially wisdom teeth, inflamed gum or palate by a bad denture and inclusion of roots or unerupted teeth; not to forget acute and chronic infection of the tonsils, sinuses and ears make a greater source of focal infection than apical abcesses. Therefore the above statement is not true and the criterium was wrong and misleading.

3. "Foci of infection, according to some statistical studies, are as common in apparently healthy persons as in those with disease".

In support of the above statement Wood gave the following statistics:

"Dental foci of infection found in 500 patients with cataract (not due to infection) as often as in 500 patients with uveitis".

After I proved that dental infection was a cause for cataract formation, Wood's statistics become consistent with my findings and in favor of the theory rather than against it.

Yet many patients have advanced foci of infection in their teeth and have no apparent systemic manifestations. There are many reasons for this apparent asymmetry or contradiction.

1) No systemic correlation was made before between foci of infection and all diseases of the body and systemic diseases were not traced back to any possible focus of infection.

2) Only apical dental abcesses were considered in most previous studies and the other foci (mentioned before) were overlooked.

3) Focal infection in its chronic form (pyorrhea, roots, pockets, etc.) works so insidiously and the manifestations may be so mild and varied that they pass unnoticed by the physician and patient.

4) Focal infection in its acute form (adopted and favoured until now), (acute tonsillitis, apical abscess etc.), produces the well known manifestations: Uveitis, bacterial endocarditis and rheumatic heart disease.

5) Most of the foci of infection are painless and are overlooked by the physician, dentist and patient as a cause for many diseases.

6) Authors are still unable to explain satisfactorily the mechanism of action of the foci of infection. Here is a brief review of the work done in this field.

- a) Asano <sup>18</sup>, demonstrated the presence of mycobacterium leprae in the dentinal tubules of leprosy patients. Smaller microorganisms like cocci can more easily invade the tubules and become well protected against effective local and systemic treatment.
- b) Macdonald <sup>19</sup>, proved that tetanus toxin sealed in the teeth of animals has penetrated the dentinocemental junction and has caused the death of experimental animals.
- c) Selye <sup>20</sup>, injected into rats various putrefied proteins and got an endocarditis and myeloid infiltration in the spleen, renal pelvis and liver. He called this: "Focal syndrome".
- d) Rosenow <sup>21</sup>, after many experiments, considered the streptococcus viridans, with its elective affinity and transmutability, responsible for the different secondary manifestations.
- e) Roulacroix <sup>22</sup> experiments on secondary reactions or "Microbes de sortie":
  - (1) Koch phenomenon (generalized T. B. after first injection of Koch bacilli and localized abscess formation only on second injection).
  - (2) Tuberculin reaction (no reaction in normal animals, generalized T. B. in infected animals).
  - (3) Sanarelli's experiment (no cholera formed after a first minimal dose of vibrios iv; cholera formed after a second minimal dose injection of vibrios or toxins).
  - (4) Chwartzman's phenomenon (no cholera formed after first minimal dose injection of vibrios; cholera and a local ulcer rich in vibrios are formed after a second subcutaneous injection of B. Proteus or B. coli).
- f) Klinger and Rosle, Berger, Ravault and Bickel <sup>23</sup>: Toxinemia theory. These authors consider that toxins (septic discharge and heterogenous proteins) act as antigens and produce antibodies by selective sensitization of organs. Inflammation is a reaction between the antigens (toxins) and the antibodies in any organ.

g) Speransky's <sup>24</sup> nervous theory experiments.

- (1) Irritation of the 2nd and 3rd branches of the trigeminal nerve with crotonoil resulted in herpes labiales, tongue abscess, conjunctivitis and otitis media.
- (2) Separation of 2nd branch from 3rd branch of trigeminal and irritation of central end resulted in edema of face and conjunctiva, inflammation of the lips and tongue, even on the other side of the face also.
- (3) Irritation of the base of the brain near tuber cinerium of a dog by a pea or glass resulted in muscular cramps previous reactions of experiments (1) and (2) and distant reactions in the lung, stomach and intestines (hemorrhages, ulcers).
- (4) Sealing of irritant (formal, croton oil, arsenical paste) in normal tooth of dog resulted in same lesions in lung, stomach and intestines.
- (5) Sealing of irritant and extraction of tooth before the manifestations appear resulted in same manifestations and the dog died.

These experiments showed clearly that irritation of the central as well as the peripheral nervous system gave similar results and that removal of the primary focus did not stop the secondary reactions. Focal infection produces two types of reactions in the eye:

- a) Infectious reactions: Chalazions, dacryocystitis, orbital abscess, etc.
- b) Vasomotor reactions: Spring catarrh, cataract changes, iritis, macular edema and degeneration, optic atrophy, vascular occlusion and hemorrhages.

These reactions are insidious and may remain latent for months or years until they are precipitated by another factor like traumatism, extraction of an infected tooth, fatigue, cold, influenza, nervousness, etc. The microbes, viruses or toxins are transmitted to the eye either by contiguity (like dacryocystitis) or by the venous circulation (like pterygium, iritis...) or by the neuro-vegetative system (like optic atrophy, etc.).

In practice, any pathology in the eye did not clear completely until the foci of infection were controlled or removed otherwise recurrence was the rule.

Most dentists and all patients care more for the element of pain in the teeth than to the quality or quantity of the pathology. As a result many bad pyorrhetic teeth, roots etc. etc. are left without radical treatment and the patient, who is the victim, is not aware of this danger.

Focal infection attacks other organs of the body other than the eye. Out of many examples on record here is the story of one I lived.

In 1933 I had a swelling of the first interphalangeal joint of the right middle finger. X-ray of the finger showed no pathology in the joint, no diagnosis was made and the finger regained its form after exercise of the finger only. In 1955 I had recurrent occasional pain in the right knee. In 1963 I had pain and swelling of the right foot and could no more wear my shoe. Blood and urine analysis was negative except for few uric acid crystals. Elastic bandage, diet poor in uric acid, and a medication to dissolve the uric acid crystals were recommended. No explanation was given to a localized swelling of only the right foot.

Since I was aware of the relation between dental pathology and rheumatic arthritis and since I had advanced pyorrhea in all my remaining teeth, I decided to extract all my teeth. After extraction, the pain and swelling of the foot disappeared and the foot and knee regained normal function. No medication was used as a treatment and no diet restriction of any degree was followed. Four years passed and no recurrence took place. An occasional fulminating precordial pain and fibrillating contractions of the left shoulder muscles and adductor muscles of the right thumb, which I used to feel from time to time disappeared completely also.

The above example in general medicine, those mentioned in my report, those reported by Oartel and many others on record show without doubt that focal infection plays a great role in the pathogenesis of many diseases of unknown origin, called essential, idiopathic, arthritic or congenital.

In the light of the above findings I recommend the following:

- a) Every physician should start the physical examination of his patient by looking for focal infection first.
- b) Foci of infection, when found, should be treated and cured completely before or together with the treatment of the disease the patient complains of.
- c) After curing or removing the primary focus, the secondary focus should be treated and cured also.
- d) Dentists should reconsider their techniques and therapy.
  - 1) Wisdom teeth with pockets or operculums should be removed because they can not be definitely cured, and remain a constant potential focus of infection.
  - 2) Caries that destroy the pulp and reach the dental nerve should be carefully watched; and devitalized, discolored, pulpless teeth should be condemned.



- 3) Pyorrhetic teeth (specially advanced pyorrhea) should be treated and definitely cured or removed.
- 4) Removable bridges should replace fixed bridges because they can be cleaned during the day and remove at night.
- 5) Dentures should have no suckers or grooves, cleaned after each meal and removed at night. Narrow dentures without palate also produce an impression in the hard palate and produce a new focus of infection.
- 6) Unerupted wisdom teeth should be X-rayed after the age of 20-25.
- 7) Infection of the tonsils, sinuses and sometimes the ears, is usually caused by infection of the teeth. Both foci should be treated and cured.
- 8) Dental infection during pregnancy should be treated and cured before delivery because it has much return on the health of the fetus and child.
- 9) Nutrition rich in calcium (milk) and vitamins A, B, C and D should be stressed by the dentist as an important factor for good healthy teeth.
- 10) Smoking digs the grave for the teeth and sick teeth dig the grave for good health. Dentists should prohibit smoking.
- 11) For a better health we need more dental care, more dentists, a higher academic standard of dentistry and more availability to the poor.
- 12) The public should be informed more about the relation between good teeth and good health and the importance of dental care in life expectancy.

Asseily Building, Solh Square

#### REFERENCES

- <sup>1</sup> British Medical Journal. D. Abs. 4:20, 1959.
- <sup>2</sup> Brunthaler, K.M.: Improvement in torticollis after elimination of dental foci; report of a case. D. Abs. 4:22, 1959.
- <sup>3</sup> Murray, M. and Stewart, W.R.: An explanation of the pathogenesis, physiology and therapy of Menieres disease. D. Abs. 4:27, 1959.
- <sup>4</sup> Berlove, I.J.: Chronic simple glaucoma associated with foci of the teeth and right antrum. Oral. Surg., Oral Med., and Oral Path., 10:500, 1957.
- <sup>5</sup> Sklaska, K., and Wachowisk, M.: Possible influence of dental foci of infection on the organ of vision. D. Abs. 3:405, 1958.
- <sup>6</sup> Stanworth, A., and McIntyre, H.: The etiology of uveitis: dental infection. D. Abs. 3:548, 1958.
- <sup>7</sup> McGavic, J.S.: Relationship of oral infection to the eye. D. Clin. North America, July, 1958, Page 527.

FOCAL INFECTION AND EYE DISEASES

- 8 Hamaguchi, T.: Focal infection and bacterid in particular from the point of view of dental disease. D. Abs. 3:105, 1958.
- 9 Mallett, S. P.: Dental foci of infection in arthritis; report of a case. Oral Surg., Oral Med., and Oral Path., 10:824, 1957.
- 10 Evans, F. J., and Chatwin, J. V. P.: Rheumatic fever following mass exodontia. D. Abs. 5:151, 1960.
- 11 Ogle, M.W. and Lydic, R.B.: Histamine as a factor in dental inflammation. U.S.A. Armed Forces M.J., 2:1357-1361, 1951.
- 12 Silecox, L.E.: The dentist and focal infection. Pennsylvania D.J., 23:6-8, 1965.
- 13 Thomas, J.W., and Syrop, N.N.: Allergy problems related to dentistry. D. Abs. 3:570, 1958.
- 14 Oartel, J. S.: Focal infection, evidence of mechanism. D. Clin. North America, November, 1960, Page 739-747.
- 15 Grossman, L.I.: Focal infection. Are oral foci of infection related to systemic disease. D. Clin. North America, November, 1960, Page 749-763.
- 16 Cecil, R.L., and Angevine, D.M.: Ann. Int. Med. 12:577, 1938.
- 17 Arnett, J.H., and Ennis, L.M.: Am. J. Sci. 185:777, 1933.
- 18 Asano, Minoru: Tama Zenchoen Leprosarium near Tokio. D. Clin. North America. November, 1960, Page 742.
- 19 Macdonald, J.B.: Eleventh Mid-Atlantic States Conference on dentistry, Hershey, Pa., April, 1960.
- 20 Selye, H., and Bois, P.: Endotheliomyelosis - an experimental model of the "focal syndrome". Oral Surg., Oral Med., and Oral Path., 10:37-51, 1957.
- 21 Rosenow,: Focal infection. *Precis de Stomatologie*, Dechaume, 1966 ed., Masson & Cie, Editeurs, 120, Boulevard Saint Germain, Paris (6e-) Page 369.
- 22 Roulacroix,: *Microbes de Sortie. Precis de Stomatologie*, Dechaume, 1966 ed., Masson & Cie, Editeurs, 120, Boulevard Saint-Germain, Paris (6e), Page 370.
- 23 Klinger and Rosle, Berger, Ravault, Bickel: *Theorie toxinienne. Precis de Stomatologie*, Dechaume, 1966 ed., Masson & Cie, Editeurs, 120, Boulevard Saint-Germain, Paris (6e), Page 371.
- 24 Eppinger, Reilly, Ricker and Speransky: *Theorie nerveuse. Precis de Stomatologie*, Dechaume, 1966 ed., Masson & Cie, Editeurs, 120, Boulevard Saint-Germain, Paris (6e), Page 372.

## CORNEAL CYLINDERS IN REFRACTIVE KERATOPLASTY \*

BY

MILTON M. KAPLAN, O. D. \*\*

HERBERT M. KATZIN, M. D. \*\*\*

New York - U. S. A.

### *ABSTRACT*

The evolution of instrumentation in refractive keratoplasty has made possible the separation of cylindrical tissue sections from the body of the cornea. The possibilities and limits of cylindrical sectioning are discussed. The technique allows for the correction of spherical, cylindrical and combined errors by double sectioning, where necessary and discarding the second section. This represents the virtual elimination of the spherical equivalent of the refractive error and the re-orientation of the astigmatism by rotating the first section before its affixation to the corneal bed. The optical rationale is fully discussed.

### *INTRODUCTION*

Techniques of surgical intervention in the presence of ametropia for the purpose of correction has a prominent place in the literature. Dr. José I. Barraquer of the Instituto Barraquer de America has shown the feasibility of altering the refractive power of the eye by refractive keratoplasty. His technique, which has

\* This project was carried out in The Eye-Bank for Sight Restoration, Inc. under a grant from the John A. Hartford Foundation, Inc. Submitted on July 10, 1968 for publication in the ARCHIVOS de la SOCIEDAD AMERICANA de OFTALMOLOGIA y OPTOMETRIA.

\*\* Research Associate, The Eye-Bank for Sight Restoration, Inc.

\*\*\* Research Director, The Eye-Bank for Sight Restoration, Inc.

been extensively reported in the literature <sup>1</sup>, consists of the removal of a corneal section with an instrument, carving the section and replacing it on the eye.

This method is the latest of many attempts in the surgical correction of ametropia. A cutting instrument is utilized to separate a section from the body of the cornea. This instrument, called the microkeratome, is used in conjunction with a suction ring and accessory devices. The microkeratome may be defined as a mechanized surgical instrument for the dissection of partial thickness grafts from the cornea. The latest prototype of the microkeratome is the "Elkat Autokeratome" <sup>2</sup>, which consists of three functional components:

1. the head,
2. the guiding fixation ring, and
3. the motor.

It is functionally and structurally akin to a carpenter's plane. A thin stainless steel blade protrudes through a slot in the steel head and moves in a reciprocating manner. This motion is imparted by an eccentric pin in the shaft of the blow-out proof motor.

A pneumatic ring is affixed to the eye. This ring is disciform and is perforated by a central hole. The bottom of the ring contains a channel through which suction is introduced so that when the ring is applied to the eye, it is held firmly in place by the suction. The cornea protrudes through the hole in the pneumatic ring. When the ring is affixed and suction applied, the autokeratome is introduced through a guiding track at the top of the ring. The ring must be situated so that the track will be oriented with the horizontal meridian of the patient's eye. This requirement is imposed by the orbital structure so that the autokeratome will not be impeded in its cutting traverse. The front of the autokeratome contains an applanation device - a flat transparent plate, easily removable and interchangeable. A series of aspheric plates has been fabricated. Each plate is plano-toric on the applanation face so that its function may be defined as semiapplanation, since it applanates only the horizontal meridian of the eye. As the cornea is semiapplanated, the tissue is molded by the plate to conform to its plano-toric face, either concave or convex. The reciprocating blade of the autokeratome carves a flat surface, so that the separated section will be meniscus-toric in form with parallel surfaces in the horizontal meridian. This section may be theoretically reconstituted for simple visualization, so that, after its removal, it re-assumes its in-vivo form. In reconstitution, it resembles a plano-cylindrical contact lens, the horizontal cross section of which reveals parallelism of the surfaces, and the vertical cross section that of either concavity or convexity.

It has been shown that a meniscus lens with parallel surfaces has negative dioptric power<sup>3</sup>. Therefore, since the relationship is always parallel in a horizontal cross section of the surfaces, there is always minus dioptric power in this meridian. The degree of this power will depend upon the thickness of the original section and the horizontal radius of curvature as determined by a K reading prior to surgery.

### *CYLINDRICAL POWER*

The cylindrical power of the corneal section is the difference between the powers of the two principal meridians. Since the power in the horizontal meridian is always minus, it may be stated that if the vertical meridian contains a greater amount of minus power than the horizontal meridian, the corneal section is to be defined as a concave cylinder. If, however, the vertical meridian contains less minus power than that of the horizontal, the section may be defined as a convex cylinder. By the same token, if the vertical meridian contains either zero or plus power, the corneal section would also be considered plus cylindrical in nature.

### *SURGICAL LIMITS*

The optical parameters of the cylindrical sections are limited by the following considerations:

1. the minimum thickness, of either edge or center of a corneal section, within the limits of surgical considerations as determined by either Barraquer or Katzin is 0.12 mm.<sup>4</sup>
2. the minimum remaining thickness in the corneal bed has been determined to be 0.15 mm.
3. the limits of corneal curvature may be taken to be the extremes of the Bausch & Lomb Keratometer: 6.49 to 9.375 mm.

The magnitude of the values concerned in this investigation may be illustrated by example. A concave cylindrical corneal section may be assigned its minimum center thickness of 0.12 mm. If one uses average minimum values for whole corneal thickness, it may be assumed that there is at least 0.60 mm. thickness at a point approximately 3 mm. distance from the pole of the cornea. This would appear a safe assumption in view of the fact that the central corneal thickness is held to be about 0.56 mm., and that of the periphery about 1.0 mm.<sup>5</sup> Assuming a remaining bed thickness of 0.15 mm., the maximum thickness at the edge of the corneal disc in the vertical meridian may be as high as 0.45 mm. (0.60 -

0.15), assuming a disc diameter of 6 mm. Therefore, the following maximum dimensional situation may be posed: A corneal disc has the following dimensions:

1. anterior radius of curvature : 7.7 mm.,
2. central thickness : 0.12 mm.,
3. section diameter : 6.0 mm.,
4. edge thickness in the horizontal meridian: 0.12 mm.,  
and
5. edge thickness in the vertical meridian: 0.46 mm.

The cylindrical power of this disc may now be determined. The dioptric power in the horizontal meridian is:

- posterior vertex power:  $-0.564$  diopters,  
anterior vertex power:  $-0.559$  diopters, and

in the vertical meridian:

- posterior vertex power:  $-28.167$  diopters,  
anterior vertex power:  $-27.860$  diopters.

Considering the paraxial anterior vertex power, a cylindrical section of these dimensions would have a cylindrical power of  $-27.300$  diopters. It may be seen, therefore, that the magnitude of a cylindrical corneal section may be quite high, within the range of limits as stated.

Variation of the vertical edge thickness in the preceding example changes the value of the concave cylinder. Therefore, if the surgeon restricted himself to the minimum thickness in the horizontal meridian, the vertex power in this meridian would remain in the magnitude of 0.50 diopters, and the dioptric power in the vertical meridian would then determine the value of the cylindrical section. This value is calculated by changing the sign of the horizontal meridional power and adding algebraically to the vertical meridional power.

#### *HORIZONTAL MERIDIONAL POWER*

In the consideration of both convex and concave cylindrical corneal sections, the two variables are the thickness and the anterior radius of curvature. There is a considerable variation in paraxial vertex power with different radii of curvature. With an assumed constant horizontal meridional thickness of 0.12 m. m. (the minimum), a series of paraxial calculations may be made to assess the variation of power with radius change. Table I shows this variation from  $-0.795$  diopters of posterior paraxial vertex power with a corneal radius of 6.50 mm. to  $-0.377$  diopters with a corneal radius of 9.40 mm. Fig. 1 reflects the values in table I.

## REFRACTIVE KERATOPLASTY

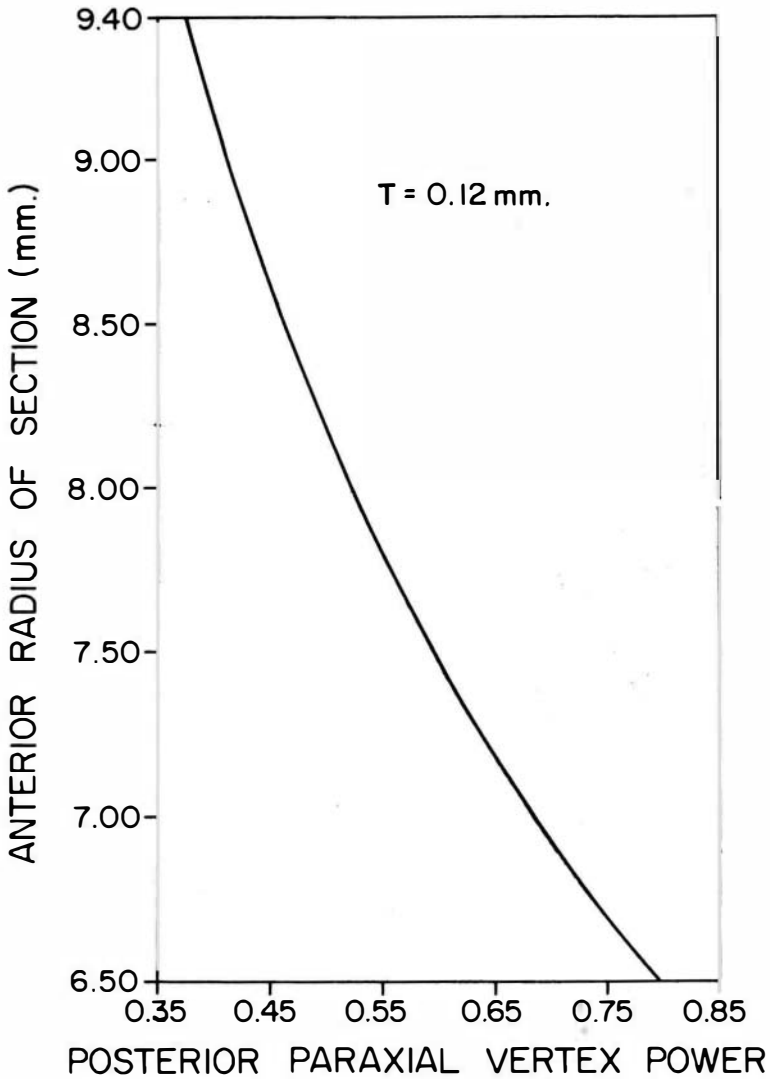

Figure 1. The relationship between the anterior radius of curvature and vertex power, in a series of corneal sections with parallel surfaces and a thickness of 0.12 mm.

The thickness of the horizontal meridian of concave cylindrical sections approaching the minimum and the horizontal meridional thickness of convex cylindrical sections approaches the maximum. An examination of the effects of thickness on paraxial vertex power may be undertaken. Table II has been calculated with an assumed horizontal radius value of 7.70 mm. (that of the Gullstrand schematic

eye "). It may be seen that the posterior paraxial vertex power varies from  $-0.564$  diopters with a thickness of  $0.12$  mm. to  $-2.185$  diopters with a thickness of  $0.44$  mm. Fig. 2 reflects the values in table II.

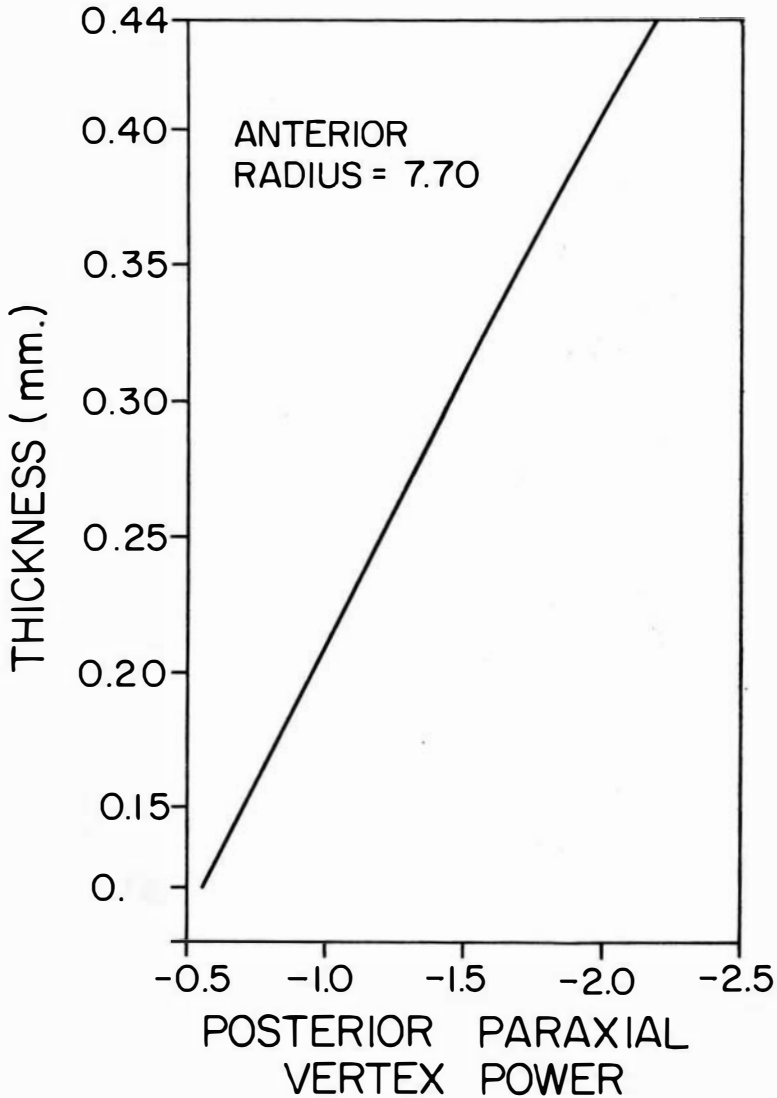
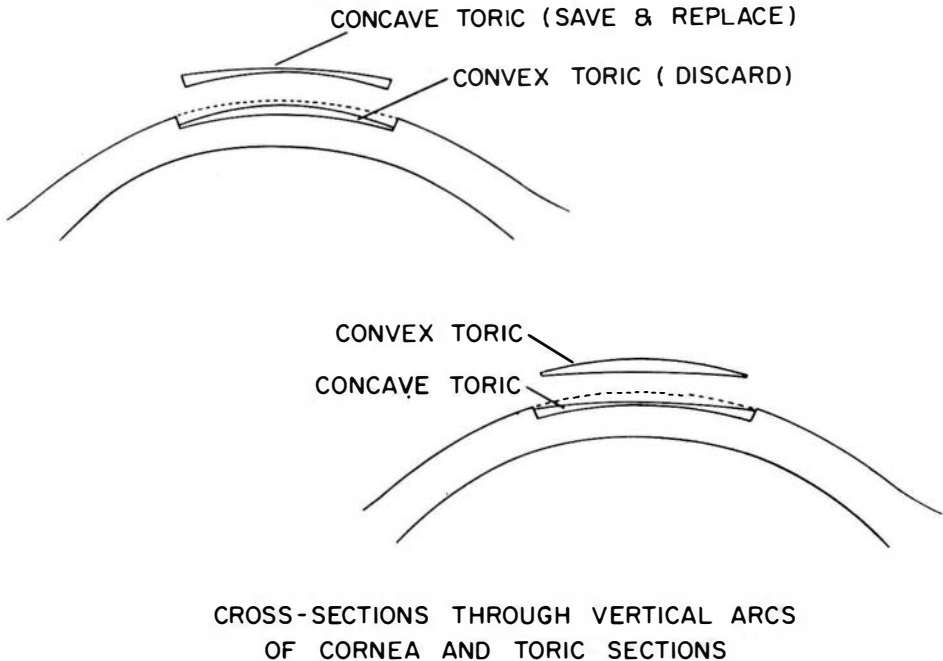

Figure 2. The relationship between thickness and vertex power in a series of corneal sections with parallel surfaces and an anterior radius of  $7.70$  mm.



*METHODS OF CORRECTION*

Single toric sectioning is a technique which consists of the separation of a toric section, its reorientation within the bed and in affixation. Double toric sectioning (fig. 3) consists of the removal of first one toric section, then the removal of a



**Figure 3. DOUBLE TORIC SECTIONING: top: correction of a + spherical equivalent error; bottom: correction of a - spherical equivalent error.**

second toric section, the discarding of the second section and the fixation of the first section to the bed with or without reorientation. Fig. 4 demonstrates the re-fixation of a toric section to the corneal bed.

Single toric sectioning is utilized in zero-equivalent, mixed astigmatia. The other categories of refractive error require double toric sectioning for their full correction.

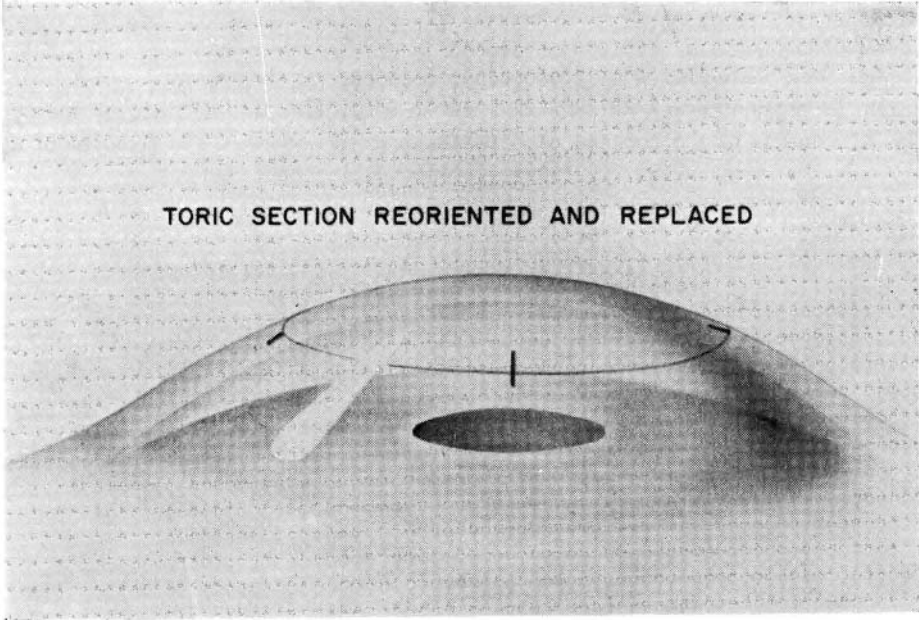

Figure 4. Refixation of a toric section to the bed of the cornea.

### OBLIQUE ASTIGMATIC ERRORS

The correction of oblique astigmatic errors requires a special understanding of the resolution of obliquely crossed cylinders. The following formulas may be applied for the resolution of obliquely crossed cylinders <sup>7</sup>:

$$P = \sqrt{F_1^2 + F_2^2 + 2F_1F_2\cos 2\gamma} \dots \dots \dots (1)$$

$$Q = \frac{F_1 + F_2 - P}{2\gamma} \quad \text{and} \dots \dots \dots (2)$$

$$\tan 2\alpha = \frac{F_2 \sin 2\gamma}{F_1 + F_2 \cos 2\gamma} \dots \dots \dots (3)$$

where the following designations prevail:

P denotes the cylindrical component of the resolved sphero-cylindrical equivalent,

Q denotes the spherical component of the resolved sphero-cylindrical equivalent,

$\alpha$  denotes the angular difference between the axis of the first oblique cylinder and the axis of the equivalent sphero-cylinder,

$F_1$  Denotes the power of the first oblique cylinder,

$F_2$  denotes the power of the second oblique cylinder, and

$\gamma$  denotes the difference between the axes of the two obliquely crossed cylinders.

The application of these formulas require that the cylinder with the smallest slope angle with relation to the horizontal meridian be assigned the value of  $F_1$ .

An example is cited from Southall <sup>8</sup>:

“Given a combination of obliquely crossed cylinders as follows:

+4.00 cyl. ax.  $20^\circ$  / -2.75 cyl. ax.  $65^\circ$ ;

“Let it be required to find the equivalent spherocylindrical power and also the equivalent cross cylinder.

We must put  $F_1 = +4.00$ , because  $F_1$  denotes the power of the cylinder whose axis-slope is the smaller of the two. Then,  $F_2 = -2.75$  and  $\gamma = (65^\circ - 20^\circ) = 45^\circ$ . Substituting these values we find:

$P = +4.85$ ,  $Q = -1.8$  and  $\gamma = -17^\circ 16'$ .

“Accordingly, the given combination is equivalent to the following:

-1.8 sphere / +4.85 cylinder axis  $2^\circ 44'$ .

### SIMPLE OBLIQUE ASTIGMIA

The problem of the correction of simple oblique astigmatism may now be examined. If a single cylindrical section were excised from the cornea of an eye with oblique astigmatism, the new error of this eye would be the resolution of the original astigmatism with minus the power of the cylindrical section removed (the section removal error). If this new error were equal to the power of the cylindrical section itself, the section would be re-oriented and sutured to its bed, effecting a correction of the astigmatic error.

Example N<sup>o</sup> 1: simple oblique myopic astigmatia:

technique of correction : single sectioning

spectacle correction :  $-1.00$  cx 15

refractive error :  $+1.00$  cx 15

power of section :  $-0.50 / +0.58$  cx 180

section removal error :  $+0.50 / -0.58$  cx 180

new refractive state :  $+1.00$  cx 15 /  $+0.50 / -0.58$  cx 180 =  
 $+1.00 / -0.58$  cx 30 section rotated to axis 30 and replaced,

power of section :  $-0.50 / +0.58$  cx 30

final refractive state :  $+1.00 / -0.58$  cx 30 /  $-0.50 / +0.58$  cx 30  
 =  $+0.50$  sphere.

It may be observed from this example that although the cylindrical component of the error was corrected in its entirety, there was some residual sphere as a result of the resolution of obliquely crossed cylinders. If, in this case, the original error was  $-0.50$  sphere /  $+1.00$  cylinder axis 15, single cylindrical sectioning would have sufficed as a theoretically adequate correcting technique.

If the original error were  $-2.00$  cylinder axis 15 (double the astigmatia in example N<sup>o</sup> 1), the power of the cylindrical section would have to have been 1.16 (double 0.58) axis 180, in order to achieve theoretically cylindrical correction, and the residual sphere would have been  $+1.00$ . Therefore, it may be seen that a table can be derived for the correction of 1.00 diopter of oblique astigmatia so that the resulting power of the cylindrical section for each axis meridian could be considered as the cylindrical factor. It would then merely be necessary to multiply the degree of oblique astigmatia in a given case by this cylindrical factor to determine the value of the cylindrical section for correction in a given case (table III).

The information contained in table III may be charted on a graph (fig. 5). It may be noted that at  $5^\circ$  and  $95^\circ$  of obliquity, the cylindrical section power is almost equal to half of the value of the original astigmatia. As the degree of obliquity increases, the value of the cylindrical section increases in a curve so that at  $45^\circ$ , the power of the correction cylinder is infinite. Above  $45^\circ$  the value of the cylindrical section begins to drop so that the values correspond exactly with those below  $45^\circ$ . It might also be noted that the value of the residual sphere as a result of single sectioning remains 0.50 diopters.

If an extreme case were chosen, an error of  $+1.00$  diopter of astigmatia axis  $40^\circ$  re-oriented and sutured back, would, in addition to correcting the astigmatia, result in a residual spherical error of  $0.50$  diopters. Therefore, by the same token as previously, if the original error were  $+0.50$  axis  $40^\circ$ , this single sectioning technique would afford complete correction.

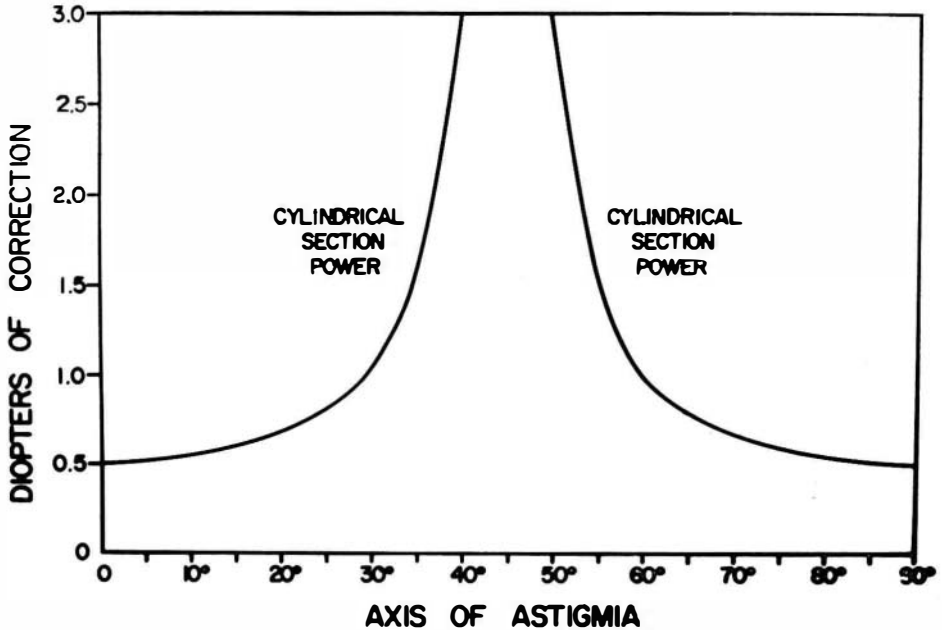

Figure 5. Power of cylindrical section necessary to correct 1.00 diopter of oblique astigmatia at various axes.

It may be concluded, therefore, that mixed, zero equivalent astigmatia at any axis lends itself to correction by single toric sectioning. For practical considerations, it may also be seen that those special cases where the residual sphere is sufficiently small, single toric sectioning may also be applied as a correcting technique. In those cases, however, where the residual sphere is considered sufficient to materially affect the outcome, it is recommended that double sectioning be applied.

*SOME GENERAL RULES*

There are two phases in the correction of refractive errors by the application of cylindrical sectioning:

1. The actual excision of a corneal lens whose spherical equivalent is equal to the spherical equivalent of the error.
2. The re-orientation of the astigmatia.

Therefore, the first section represents the corneal lens containing the astigmatia to be re-oriented and the second represents the error which is discarded.

*ZERO-EQUIVALENT ASTIGMIA*

Since the spherical equivalent is zero-equivalent astigmatia is zero, nothing need be discarded in its correction. The entire correction is achieved by the re-orientation of the astigmatia.

*Non-Oblique*

1. The error is recorded with the cylinder axis at 180°, transposing, if necessary.
2. The cylindrical component of the section to be removed has the same sign and is one-half the value of the cylindrical component of the refractive error.
3. The section is rotated 90° and affixed to the bed.

Example N<sup>o</sup> 2: zero-equivalent, non-oblique, mixed, with the rule astigmatia (fig. 6):

technique of correction : single sectioning

spectacle correction : +2.00 / -4.00 cx 180

refractive error : -2.00 / +4.00 cx 180

spherical equivalent : zero

power of section : -0.50 / +2.00 cx 180

section removal error : +0.50 / -2.00 cx 180

new refractive state :

-2.00 / +4.00 cx 180 / +0.50 / -2.00 cx 180 = -1.50 / +2.00  
cx 180

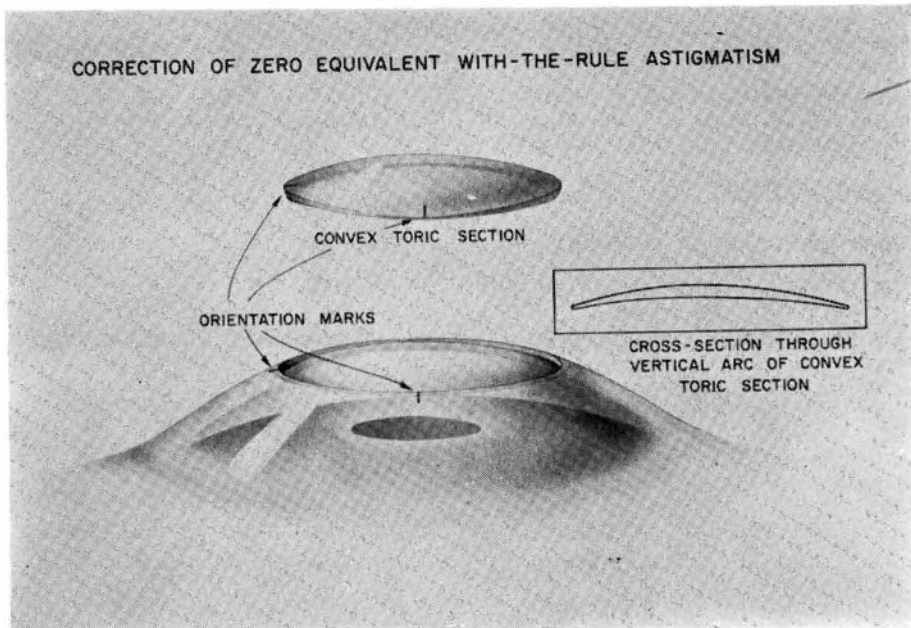

Figure 6. Correction of zero-equivalent, non-oblique, mixed, with-the-rule astigmatia.

transposed to :  $+0.50 / -2.00 \text{ cx } 90$

section re-oriented  $90^\circ$  and replaced

power of section :  $-0.50 / +2.00 \text{ cx } 90$

final refractive state :

$+0.50 / -2.00 \text{ cx } 90 / -0.50 / +2.00 \text{ cx } 90 = \text{emmetropia}$

Example N<sup>o</sup> 3: zero-equivalent, non-oblique, mixed, against the-rule astigmatia (fig. 7):

technique of correction : single sectioning

spectacle correction :  $+2.00 / -4.00 \text{ cx } 90$

refractive error :  $-2.00 / +4.00 \text{ cx } 90$

transposed to :  $+2.00 / -4.00 \text{ cx } 180$

spherical equivalent : zero

power of section :  $-0.50 / -2.00 \text{ cx } 180$

section removal error :  $+0.50 / +2.00 \text{ cx } 180$

new refractive state :

$+2.00 / -4.00 \text{ cx } 180 / +0.50 / +2.00 \text{ cx } 180 = +2.50 / -2.00 \text{ cx } 180$

transposed to :  $+0.50 / +2.00 \text{ cx } 90$

section re-oriented  $90^\circ$  and replaced

power of section :  $-0.50 / -2.00 \text{ cx } 90$

final refractive state :

$+0.50 / +2.00 \text{ cx } 90 / -0.50 / -2.00 \text{ cx } 90 = \text{emmetropia}$

Zero- Equivalent, Oblique, Mixed Astigmatia

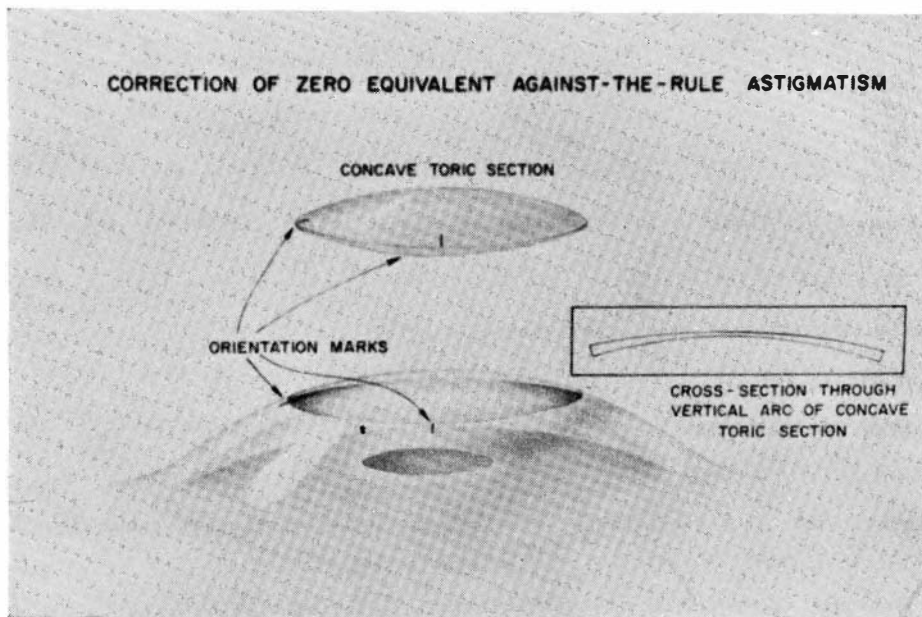

Figure 7. Correction of zero-equivalent, non-oblique, mixed, against-the-rule astigmatia.

1. The error is recorded to that the axis falls between  $0^\circ$  and  $90^\circ$ , transposing, if necessary.

2. Fig. 3 is consulted to determine the cylindrical factor, using the oblique axis of the astigmatic component of the error as a point of reference.



3. The power of the cylindrical section to be removed is determined by multiplication of the cylindrical factor from step 2 by the cylindrical component of the original refractive error.

a. If the oblique axis is between  $0^\circ$  and  $45^\circ$ , the sign of the cylindrical section is the same as that of the cylindrical component of the error.

b. If the oblique axis is between  $45^\circ$  and  $90^\circ$ , the sign of the cylindrical section is opposite that of the cylindrical component of the error.

4. The axis of re-orientation is determined by doubling the axis of the original error and reversing  $90^\circ$ .

Example N<sup>o</sup> 4: zero-equivalent, oblique, mixed astigmatia:

technique of correction : single sectioning

spectacle correction :  $+2.00 / -4.00$  cx 35

refractive error :  $-2.00 / +4.00$  cx 35

spherical equivalent : zero

power of section :  $-0.50 / +5.86$  cx 180

section removal error :  $+0.50 / -5.86$  cx 180

new refractive state :

$-2.00 / +4.00$  cx 35 /  $+0.50 / -5.86$  cx 180 =  $+0.50 / -5.86$  cx 160

section re-oriented to axis 160 and replaced power of section :  $-0.50 / +5.86$  cx 160

final refractive state :

$+0.50 / -5.86$  cx 160 /  $-0.50 / +5.86$  cx 160 = emmetropia

### SPHERICAL ERRORS

The following method may be applied for the correction of spherical errors:

1. The spherical equivalent of the second section is equal to the ametropia to be corrected.

a. The spherical component of the second section may be assigned an arbitrary value of  $-0.50$ .

b. The cylindrical component of the second section is derived by adding  $+0.50$  algebraically to the ametropia and doubling the result.

2. The power of the cylindrical component of the first section is one-half that of the cylindrical component of the second section.

3. The second section is discarded.

4. The first section is rotated 90° and affixed to the bed of the cornea.

Example N<sup>o</sup> 5 (fig. 8): simple myopia

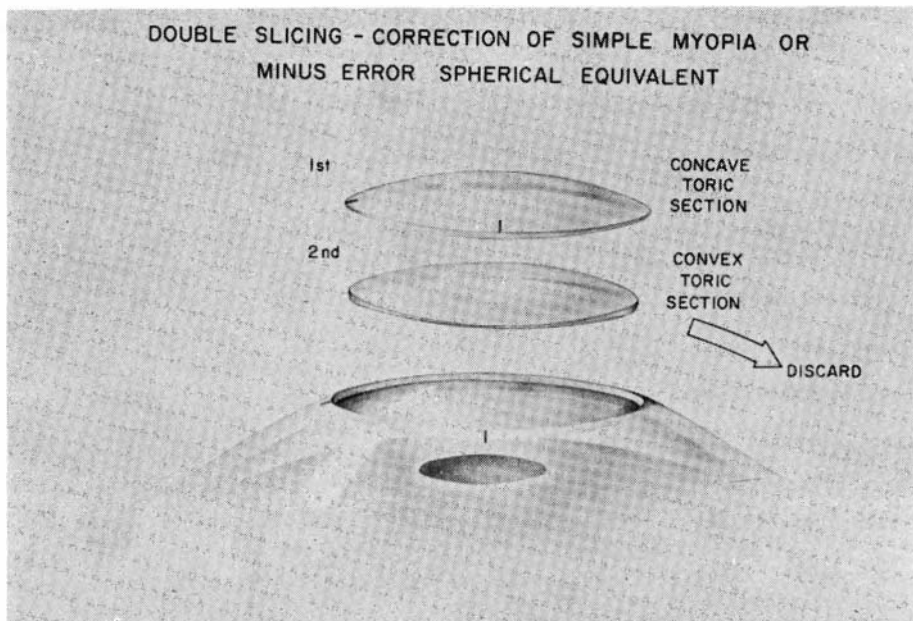

Figure 8. Correction of simple myopia.

technique of correction : double sectioning

spectacle correction :  $-2.00$  sphere

power of 1st section :  $-0.50 / -2.50$  cx 180

section removal error :  $+0.50 / +2.50$  cx 180

new refractive state :

$+2.00 / +0.50 / +2.50$  cx 180

$= +2.50 / +2.50$  cx 180

REFRACTIVE KERATOPLASTY

power of 2nd section :  $-0.50 / +0.50 / +5.00 \text{ cx } 180$

section removal error :  $+0.50 / -5.00 \text{ cx } 180$

new refractive state :

$+2.50 / +2.50 \text{ cx } 180 / +0.50 / -5.00 \text{ cx } 180$

$= +3.00 / -2.50 \text{ cx } 180$

transposed to :  $+0.50 / +2.50 \text{ cx } 90$

2nd section discarded, 1st section replaced, reoriented to axis 90

power of 1st section :  $-0.50 / -2.50 \text{ cx } 90$

final refractive state :

$+0.50 / +2.50 \text{ cx } 90 / -0.50 / -2.50 \text{ cx } 90$

$= \text{emmetropia}$

Example N° 6: (fig. 9) simple hyperopia

technique of correction : double sectioning

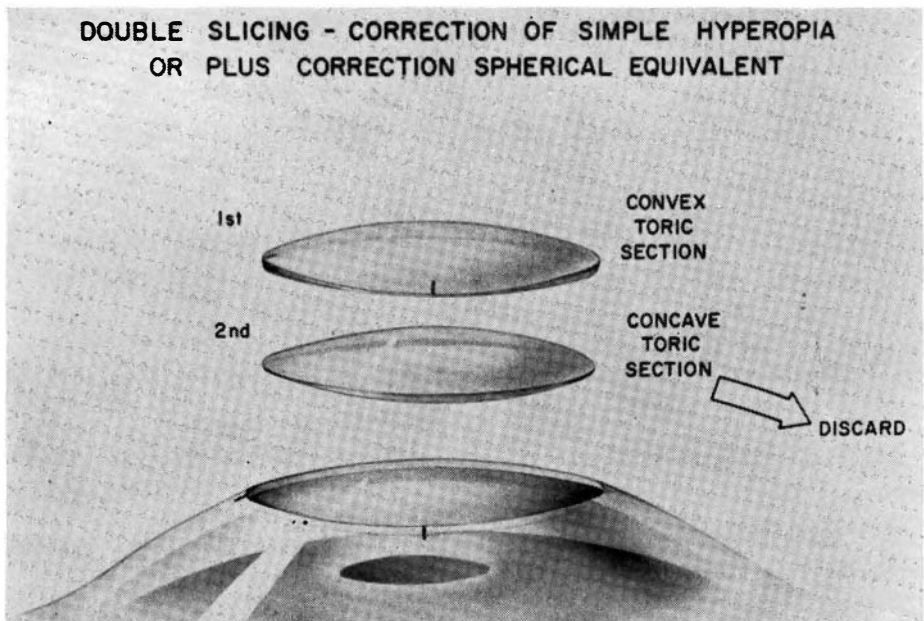

Figure 9. Correction of simple hyperopia.

spectacle correction : +2.00 sphere  
 refractive error : -2.00  
 power of 1st section : -0.50 / +1.50 cx 180  
 section removal error : +0.50 / -1.50 cx 180  
 new refractive state :  
     -2.00 +0.50 / -1.50 cx 180  
     = -1.50 / cx 180  
 power of 2nd section : -0.50 / -3.00 cx 180  
 section removal error : +0.50 / +3.00 cx 180  
 new refractive state :  
     -1.50 / -1.50 cx 180 / +0.50 / +3.00 cx 180  
     = -1.00 / +1.50 cx 180  
 transposed to : +0.50 / - 1.50 cx 90  
 2nd section discarded, 1st section replaced,  
     re-oriented to axis 90  
 power of 1st section : -0.50 / +1.50 cx 90  
 final refractive state :  
     +0.50 / -1.50 cx 90 / -0.50 / +1.50 cx 90  
     = emmetropia

*NON-OBLIQUE, NON-ZERO-EQUIVALENT, REFRACTIVE ERRORS*

1. The error is recorded with the cylinder axis at 180°, transposing, if necessary.
2. The spherical equivalent of the second section is equal to the ametropia (spherical equivalent) to be corrected.
  - a. The spherical component of the second section may be assigned an arbitrary value of -0.50.

b. The cylindrical component of the second section is derived by adding  $+0.50$  algebraically to the spherical equivalent of the ametropia and doubling the result.

3. The power of the first section may be derived in the following manner:

a. The spherical component of the first section may be assigned an arbitrary value of  $-0.50$ .

b. The cylindrical component of the first section is that value half-way between the cylindrical components of the original refractive error and the second section, the sign opposite to that of the second section.

4. The second section is discarded.

5. The first section is rotated  $90^\circ$  and affixed to the bed of the cornea.

Example N<sup>o</sup> 7: simple, with-the-rule, axis 90 astigmatia

technique of correction:	double sectioning
spectacle correction	: $+2.00$ cx $90$
refractive error	: $-2.00$ cx $90$
transposed to	: $-2.00$ / $+2.00$ cx $180$
spherical equivalent	: $-1.00$
power of 1st section	: $-0.50$ / $+1.50$ cx $180$
section removal error	: $-0.50$ / $+1.50$ cx $180$
new refractive state	:
	$-2.00$ / $+2.00$ cx $180$ / $+0.50$ / $-1.50$ cx $180$
	$= -1.50$ / $+0.50$ cx $180$
power of 2nd section	: $+0.50$ / $-1.00$ cx $180$
section removal error	: $+0.50$ / $+1.00$ cx $180$
new refractive state	:
	$-1.50$ / $+0.50$ cx $180$ / $+0.50$ / $+1.00$ cx $180$
	$= -1.00$ / $+1.50$ cx $180$

transposed to : +0.50 / -1.50 cx 90  
 2nd section discarded, 1st section replaced, re-oriented to axis 90  
 power of 1st section : -0.50 / + 1.50 cx 90  
 final retractive state:  
 +0.50 / -1.50 cx 90 / -0.50 / +1.50 cx 90  
 = emmetropia

Example N<sup>o</sup> 8: compound, with-the-rule, myopic astigmatia:

technique of correction : double sectioning  
 spectacle correction : -1.00 / -2.00 cx 90  
 refractive error : +1.00 / +2.00 cx 90  
 transposed to : +3.00 / -2.00 cx 180  
 spherical equivalent : +2.00  
 power of 1st section : -0.50 / -3.50 cx 180  
 section removal error : +0.50 / +3.50 cx 180  
 new refractive state :  
 +3.00 / -2.00 cx 180 / +0.50 / +3.50 cx 180  
 = +3.50 / +1.50 cx 180  
 power of 2nd section : -0.50 / +5.00 cx 180  
 section removal error : +0.50 / -5.00 cx 180  
 new refractive state:  
 +3.50 / +1.50 cx 180 / +0.50 / -5.00 cx 180  
 = +4.00 / -3.50 cx 180  
 transposed to : +0.50 / +3.50 cx 90  
 2nd section discarded, 1st section replaced, re-oriented to axis 90  
 power of 1st section : -0.50 / -3.50 cx 180  
 final refractive state: :  
 +0.50 / +3.50 cx 90 / -0.50 / -3.50 cx 90  
 = emmetropia

*NON-ZERO-EQUIVALENT, OBLIQUE REFRACTIVE ERRORS*

1. The error is recorded so that the axis falls between  $0^{\circ}$  and  $90^{\circ}$ , transposing, if necessary.

2. The spherical equivalent of the second section is equal to the spherical equivalent of the ametropia.

a. The spherical component of the second section may be assigned an arbitrary value of  $-0.50$ .

b. The cylindrical component of the second section is derived by adding  $+0.50$  algebraically to the spherical equivalent of the ametropia and doubling the result.

3. The negative power of the second section (the section removal error) as derived in step 2, is resolved with the original refractive error.

4. The cylindrical factor is determined from the graph (fig. 3) using the axis of resolution determined in step 3 as the reference.

5. The cylindrical factor from step 4 is multiplied by the cylindrical component of the resolution from step 3. This value is the power of the cylindrical component of the first section.

a. If the oblique axis of the original error is between  $0^{\circ}$  and  $45^{\circ}$ , the sign of the first section is opposite that of the cylindrical component of the original error.

b. If the oblique axis of the original error is between  $45^{\circ}$  and  $90^{\circ}$ , the sign of the first section is the same as that of the cylindrical component of the original error.

c. The spherical component of the first section may be assigned an arbitrary value of  $-0.50$ .

6. The removal error of the first section (the negative value from step 5) is resolved with the original refractive error.

7. The removal error of the second section (the negative value from step 2) is resolved with the resolution from step 6.

8. The axis of this resolution (step 7) represents the axis of re-orientation of the first section.

9. The first section (from step 5) is then separated and retained, the second section (from step 2) separated and discarded, the first section re-oriented to the axis (from step 8) and affixed to the corneal bed.

Example N<sup>o</sup> 9:: compound, myopic, oblique, with-the-rule astigmatia:  
technique of correction: double sectioning

$$\begin{aligned}
 \text{spectacle correction} & : -2.00 / -1.00 \text{ cx } 25 \\
 \text{refractive error} & : +2.00 / +1.00 \text{ cx } 25 \\
 \text{spherical equivalent} & : +2.50 \\
 \text{power of 2nd section} & : -0.50 / +6.00 \text{ cx } 180 \\
 \text{section removal error} & : -0.50 / +6.00 \text{ cx } 180 \\
 \text{resolution of section removal error and original error} & \\
 +2.00 / +1.00 \text{ cx } 25 / +0.50 / -6.00 \text{ cx } 180 & \\
 = +2.707 / -5.414 \text{ cx } 86 &
 \end{aligned}$$

$$\text{cylindrical factor} : 0.5064$$

cylindrical component of last section

$$\text{cylindrical component of 1st section} : (-5.414) (+0.5064) = -2.742$$

$$\text{power of 1st section} : -0.50 / -2.742 \text{ cx } 180$$

$$\text{section removal error} : +0.50 / +2.742 \text{ cx } 180$$

resolution of 1st section removal error and original error :

$$+0.50 / +2.742 \text{ cx } 180 / +2.00 / +1.00 \text{ cx } 25$$

$$= +2.636 / +3.468 \text{ cx } 6$$

resolution of 2nd section removal error and new refractive state :

$$+0.50 / -6.00 \text{ cx } 180 / +2.636 / +3.468 \text{ cx } 6$$

$$= +0.49 / +2.752 \text{ cx } 172$$

2nd section discarded, 1st section replaced, re-oriented to axis 172

$$\text{final refractive state} : +0.49 / +2.752 \text{ cx } 172 / -0.50 / -2.742 \text{ cx } 172$$

$$= -0.01 / +0.01 \text{ cx } 172$$

$$= \text{emmetropia}^*$$

\* (If the decimal limit of the calculation were increased, the new refractive state would more closely approach zero).



*QUALIFICATIONS*

If the cylindrical section is reconstituted to its pre-separation dimensions, it is apparent that the posterior principal meridional radii of the section will not match the anterior principal meridional radii of the bed. This is true in both single and double sectioning. The section must bend from its pre-separation dimensions so that its posterior face conforms to the corneal bed. This bending changes the dioptric power of the section <sup>9</sup>. Bending effects have been excluded from this discussion, so that the examples cited herein do not reflect this order of change. Bending, however, must be taken into consideration when computing a given case.

These calculations are also subject to biological variation. Factors involving the accuracy of this form of surgical intervention are in the process of assessment by members of the Katzin team\* in the biological experimentation phase of their studies in refractive keratoplasty. The plus or minus error limits include:

1. sectioning accuracy,
2. re-orientation accuracy,
3. suture balance (so as not to induce corneal distortion) and
4. healing distortion.

*CONCLUSION*

This calculation rationale is a starting point in the biological experimentation phase of cylindrical sectioning techniques in refractive keratoplasty. Any trauma associated with freezing, lathe-carving, the excessive handling of the corneal tissue section, and the additional time necessary for the performance of these techniques, is eliminated by the application of cylindrical sectioning. The upper limits of correction possible with frozen-lathe-carving are not attainable with double cylindrical sectioning. This is a consequence of the necessary minimum edge or center

\* A team of researchers under the direction of Dr. Herbert M. Katzin working on refractive keratoplasty at The Eye-Bank for Sight Restoration, Inc., under a grant from the John A. Hartford Foundation, Inc.

thickness in the second section. It is the feeling of some of those associated with this work that if any considerations of cylindrical sectioning will minimize interface opacification, this procedure may be preferable in those cases within the optical limits of this schema.

TABLE I

$r_a$	$r_p$	$D_p$	$D_a$
6.50	6.38	-0.795	-0.787
6.60	6.48	-0.770	-0.763
6.70	6.58	-0.748	-0.741
6.80	6.68	-0.725	-0.718
6.90	6.78	-0.704	-0.698
7.00	6.88	-0.684	-0.678
7.10	6.98	-0.665	-0.659
7.20	7.08	-0.646	-0.640
7.30	7.18	-0.628	-0.623
7.40	7.28	-0.611	-0.606
7.50	7.38	-0.595	-0.590
7.60	7.48	-0.579	-0.574
7.70	7.58	-0.564	-0.559
7.80	7.68	-0.550	-0.545
7.90	7.78	-0.536	-0.531
8.00	7.88	-0.522	-0.518
8.10	7.98	-0.509	-0.505
8.20	8.08	-0.497	-0.493
8.30	8.18	-0.485	-0.481
8.40	8.28	-0.473	-0.470
8.50	8.38	-0.462	-0.459
8.60	8.48	-0.451	-0.448
8.70	8.58	-0.441	-0.438
8.80	8.68	-0.431	-0.428
8.90	8.78	-0.421	-0.418
9.00	8.88	-0.412	-0.409
9.10	8.98	-0.403	-0.400
9.20	9.08	-0.394	-0.391
9.30	9.18	-0.385	-0.383
9.40	9.28	-0.377	-0.375

A series of corneal sections with parallel surfaces and thickness of 0.12 mm. where the following designations prevail:  $r_a$  and  $r_p$  are the anterior and posterior radii of curvature, respectively;  $D_a$  and  $D_p$  are the anterior and posterior paraxial vertex powers, respectively.

## REFRACTIVE KERATOPLASTY

TABLE II

$r_n$	$t$	$D_p$	$D_a$
7.58	0.12	-0.564	-0.559
7.57	0.13	-0.612	-0.607
7.56	0.14	-0.661	-0.654
7.55	0.15	-0.709	-0.701
7.54	0.16	-0.756	-0.749
7.53	0.17	-0.806	-0.796
7.52	0.18	-0.855	-0.844
7.51	0.19	-0.904	-0.892
7.50	0.20	-0.953	-0.953
7.49	0.21	-1.000	-0.987
7.48	0.22	-1.052	-1.035
7.47	0.23	-1.102	-1.084
7.46	0.24	-1.152	-1.132
7.45	0.25	-1.202	-1.180
7.44	0.26	-1.252	-1.228
7.43	0.27	-1.302	-1.277
7.42	0.28	-1.353	-1.326
7.41	0.29	-1.403	-1.374
7.40	0.30	-1.454	-1.423
7.39	0.31	-1.505	-1.472
7.38	0.32	-1.556	-1.521
7.37	0.33	-1.608	-1.570
7.36	0.34	-1.659	-1.619
7.35	0.35	-1.711	-1.668
7.34	0.36	-1.763	-1.718
7.33	0.37	-1.815	-1.767
7.32	0.38	-1.868	-1.817
7.31	0.39	-1.920	-1.866
7.30	0.40	-1.973	-1.916
7.29	0.41	-2.025	-1.966
7.28	0.42	-2.078	-2.016
7.27	0.43	-2.132	-2.066
7.26	0.44	-2.185	-2.116

A series of corneal sections - anterior radius of curvature: 7.70 mm. with parallel surfaces where the following designations prevail:  $r_p$  is the posterior radius of curvature,  $t$  is the thickness and  $D_a$  and  $D_p$  are the anterior and posterior paraxial vertex powers, respectively.

TABLE III

<i>axis</i>	<i>cylinder*</i>	<i>sign**</i>	<i>sphere***</i>	<i>sign****</i>	<i>new axis</i>
5	0.509	same	0.50	opp.	10
10	0.535	same	0.50	opp.	20
15	0.580	same	0.50	opp.	30
20	0.655	same	0.50	opp.	40
25	0.780	same	0.50	opp.	50
30	1.000	same	0.50	opp.	60
35	1.464	same	0.50	opp.	70
40	2.900	same	0.50	opp.	80
45	infinite				
50	2.900	opp.	0.50	same	100
55	1.464	opp.	0.50	same	110
60	1.000	opp.	0.50	same	120
65	0.780	opp.	0.50	same	130
70	0.655	opp.	0.50	same	140
75	0.580	opp.	0.50	same	150
80	0.535	opp.	0.50	same	160
85	0.509	opp.	0.50	same	170

Correction of 1.00 diopter of zero-equivalent, oblique astigmatism where the following designations prevail: cylinder\* is the power of the cylindrical section; sign\*\* is the sign of the cylindrical section (+ or -); sphere\*\*\* is the value of the residual sphere; sign\*\*\*\* is the sign of the residual sphere; new axis is the axis of re-orientation.

New York-210 East  
Sixty fourth Street.

BIBLIOGRAPHY

1. BARRAQUER, JOSE I., Basis of Refractive Keratoplasty, Arch. Soc. Amer. Otol. Optom., (1967), 6.
2. ELSTEIN, JACOB K., Condensed Description of the Autokeratome, Theta Instr. Corp., Fairfield, N. J. 1968.
3. KAPLAN, MILTON M., Optical Considerations of Hydrogel Contact Lenses, Optom. Wkly., (Apr. 7, 1966), 57/14.
4. KATZIN, HERBERT M., Refractive Keratoplasty, 2nd Annual Progress Report to the John A. Hartford Foundation (Apr. 1, 1967).
5. DUKE-ELDER, STEWART. System of Ophthalmology, Vol. II, The Anatomy of the Visual System, The C. V. Mosby Co., St. Louis, (1961).
6. VON HELMHOLTZ, HERMAN LUDWIG, Treatise on Physiological Optics, trans. from the 3rd German Ed. by James P. C. Southall, Dover Publications, New York (1962).
7. THOMPSON, S. P., On Obliquely Crossed Cylinders, Phil. Mag., (1900) 5/49.
8. SOUTHALL, JAMES P. C., Mirrors, Prisms and Lenses, 3rd Ed., Dover Publications, New York (1964).
9. KAPLAN, MILTON M., ELSTEIN, JACOB K., SEHGAL, VISHWA N. and KATZIN, HERBERT M., Refractive Keratoplasty —Corneal Bending, in press.

# REFRACTIVE KERATOPLASTY - VERGENCY CALCULATIONS

BY

MILTON M. KAPLAN, O.D.,

New York U. S. A.

## INTRODUCTION

Refractive keratoplasty is being undertaken in a clinic in Bogota, Colombia and at the Eye Bank Laboratory of the Manhattan Eye, Ear and Throat Hospital in New York. The technique, as practiced, consists of removing a corneal section with an instrument called the microkeratome, carving the section and replacing it on the eye.

Dr. José I. Barraquer of the Instituto Barraquer de America, carves his sections on a lathe, the technique resembling the initial step in the manufacture of contact lenses. Martinez and Katzin <sup>1</sup> have developed techniques of flat slicing and carving on a freezing microtome. This paper will concern itself with the calculations in the technique of lathe-carving the corneal section.

Barraquer <sup>2, 3</sup>, in his original work, has developed a calculation rationale which needed an empirical correction to insure relative accuracy in the outcome, insofar as refractive considerations are concerned. It is the goal of Dr. Herbert M. Katzin <sup>4</sup> and his group \* (see footnote) to precalculate the parameters concerned in the successful completion of this technique.

\* a team of researchers developing techniques and refinements for refractive keratoplasty at the Manhattan Eye, Ear & Throat Hospital.

## SURGICAL TECHNIQUE

A brief description of the surgery might be in order at this time. To begin, a speculum is inserted and fixed. A pneumatic ring (figure N<sup>o</sup> 1) is then affixed to the eye. This ring is actually a cylinder with a disc top. The disc is perforated by a central hole. The open end of the cylinder is placed on the globe. This cylinder is preselected by dimension based on certain considerations which are extraneous to the discussion at hand. The pneumatic rings are available in sets of different sizes for different topographies. One of the considerations in the selection of the appropriate size ring is that the cornea shall protrude through the perforation in the disc a top the cylinder, and the fit will produce sufficient vacuum for fixation. This protrusion shall be sufficient so that almost the entire cornea will protrude and when the cornea is applanated, the diameter of applanation shall approximate 9 mm. Therefore, as the cornea is pressed down by a flat surface, somewhat above the level of the disc, the diameter of the cornea that is flattened by the applanation device will be 9 mm. The top of the disc portion of the pneumatic ring contains a small track in the form of a dovetail.

After the correct size ring has been determined, it is placed in its position on the globe and suction is applied. This section will have the function of affixing the ring tightly to the globe. If the ring is moved, the globe will move with it so that the orientation of the protruding cornea is constant with respect to the ring.

The microkeratome is constructed on the principle of a carpenter's plane. The front portion of the instrument serves as an applanation device. It presses down the protruding section of cornea so that it approximates a flat surface. The blade that protrudes through the plane is electrically driven so that it rapidly moves from side to side as the microkeratome is advanced. This action is actually reciprocating on the part of the blade. As the blade is advanced (figure N<sup>o</sup> 2), a disc is shaved from the cornea which is 8 to 9 mm. in diameter, round and with parallel surfaces. This disc is then removed from the microkeratome, and placed in a solution containing 10% glycerine and from 0.5 to 1.0% of green dye to induce color into the section. The solution containing the section is then placed in a chamber at 0° C. to prepare it for freezing. It is removed from this chamber after 10 minutes and then the corneal disc is removed from the solution and placed on a concave lap in a lathe. The disc is then spun on the lap to flatten it out, drive the excess solution from the tissue and help center it on the lap. The lathe has been fitter with tubing for freezing gas to act upon the lap and the cutting tip. The freezing gas is then applied and the posterior surface of the corneal section (exposed to the cutting tip) is then carved to a new radius. It is not only necessary to carve a new radius - it is also necessary

REFRACTIVE KERATOPLASTY

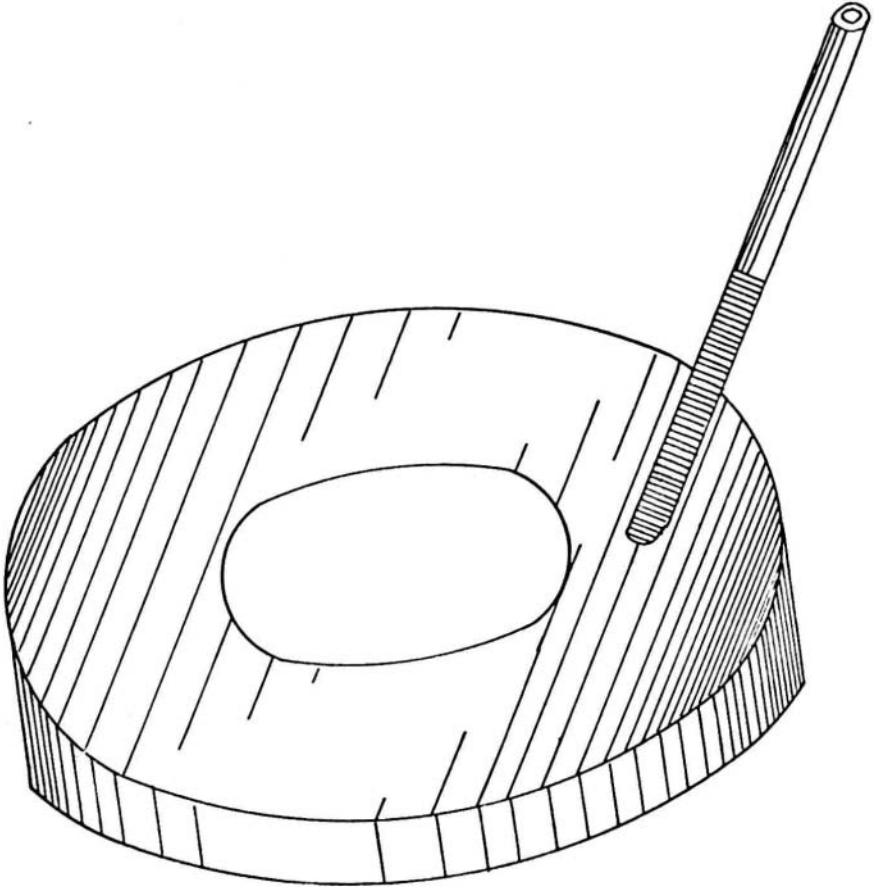

Fig. 1. PNEUMATIC RING through which suction is introduced as it is placed on the globe, to provide fixation and a base for the microkeratome.

to control the remaining edge or center thickness of the corneal section (to correct myopia or hyperopias the case may be), and also to control the diameter of the carving itself. It is sometimes not desirable to carve to the periphery of the corneal section.

After the carving has been completed, the frozen lap with corneal section affixed is removed from the lathe and the corneal section is bathed with normal saline solution at a temperature of 37° C. This serves to thaw the section, after which it is replaced on to its bed and sutured back to the eye.

The stitches are removed after 7 days and the cornea epithelizes 48 hours later.

### INITIAL CONSIDERATIONS

There are a number of approaches in calculating the appropriate changes in carving the cornea by the lathing technique. The best overall approach appeared to be the consideration of the disc in air after its removal from the cornea itself. Two basic results are necessary to determine the accuracy of the carving. The first is the refractive power of the disc in air before surgery, and then the calculation of the refractive power in air after surgical intervention. Some assumptions are necessary before this approach is used.

Firstly, it must be assumed that the surfaces of the corneal disc are parallel. Even though the cornea is applanated by the microkeratome in advance of the cutting edge of the blade, it is somewhat doubtful that the slice will have exactly parallel surfaces. Since the force of applanation at the pole will exceed the force of applanation at the periphery, it is likely that there will be some compression of the corneal tissue at the pole to a greater extent than at the periphery. It is likely, then, that the corneal section, rather than having parallel surfaces will actually be thicker at the center. This projection applies to the relaxed state of the section. When the compression is released as the section is separated from the body of the eye, it is advanced that the portion which has been subjected to the greater compression will assume a greater thickness than the portion subjected to a minimum compression - as a result of the resiliency of the tissue.

The second assumption to be made is with respect to the optical homogeneity of the section. The literature states that the layers of the cornea are isoindicial. This assumption, therefore, appears to be fairly safe.

The third assumption is made with respect to the thickness of the section. The microkeratome that is currently in use is designed to cut a section of 0.4 mm. in thickness. The thickness, however, is subject to some variation. This variation will occur as a result of either technique or changes in intraocular tension. The



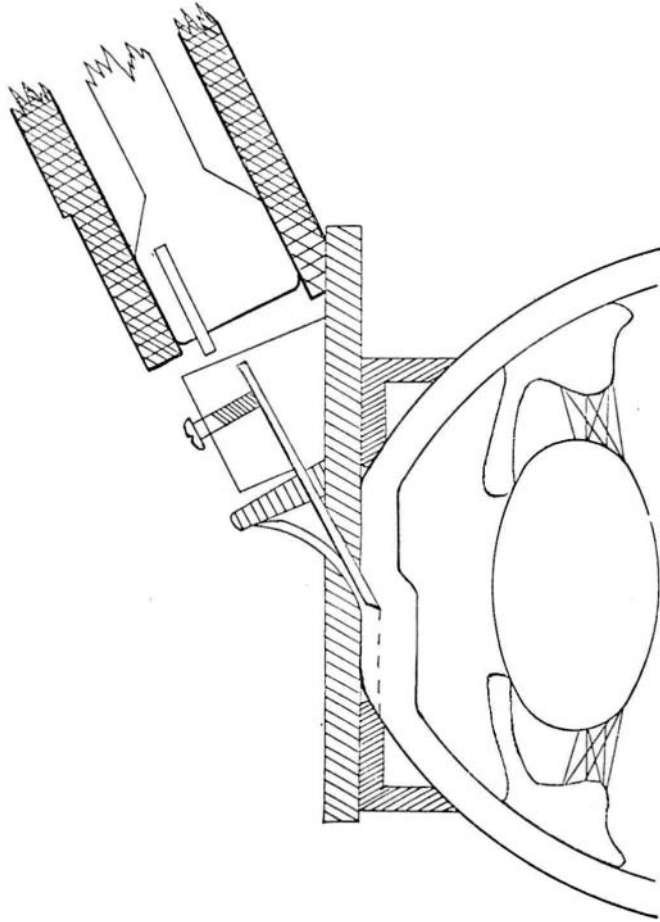

Fig. 2. THE MICROKERATOME advancing across the pneumatic ring shaving a corneal disc from the eye.

intraocular tension is determined before the microkeratome is applied to the ring. The latest technology dictates an optimum intraocular tension of from 40 to 60 mm. of mercury before the slice is taken. This high intraocular tension is a direct consequence of the suction applied to the pneumatic ring. The intraocular tension may be controlled by varying the degree of vacuum from the suction pump and motor. The thickness assumption of 0.4 mm. is merely made for the initial analysis. It will be shown later that the actual thickness for the purposes of the initial calculation is unimportant, as it fall out of the calculation after the first comparisons are made. The later phases of the calculation do, however, require a knowledge of the thickness of the corneal section in each instance.

The fourth assumption to be made is that the corneal section will assume a relaxed state identical in curvature to its form before it was removed. Therefore, if the K reading displayed a spherical cornea of 7.5 mm. radius before the surgery, it is assumed that after the section is removed it will display a radius of 7.5 mm. in air with respect to its anterior surface.

## OPTICAL CALCULATIONS

### Before Surgery

The following paraxial formulae may be applied in arriving at the posterior vertex power of the corneal section before it has been subjected to carving (figure N<sup>o</sup> 3) :

$$r_p = r_a - t \dots\dots\dots (1)$$

$$f_1 = \frac{r_a}{n' - n} \dots\dots\dots (2)$$

$$f_2 = f_1 \cdot t/n' \dots\dots\dots (3)$$

$$F_2 = 1/f_2 \dots\dots\dots (4)$$

$$F_p = \frac{n - n'}{r_p} \dots\dots\dots (5)$$

$$D_{bs} = F_2 + F_p \dots\dots\dots (6)$$

where:

$r_p$  is the mean radius of the posterior surface,

\* $r_a$  is the mean radius of the anterior surface (see footnote),

\* the mean radius of curvature of the cornea shall be taken to be a value midway between the radii of two principle meridians of the K reading (see example N<sup>o</sup> 1).

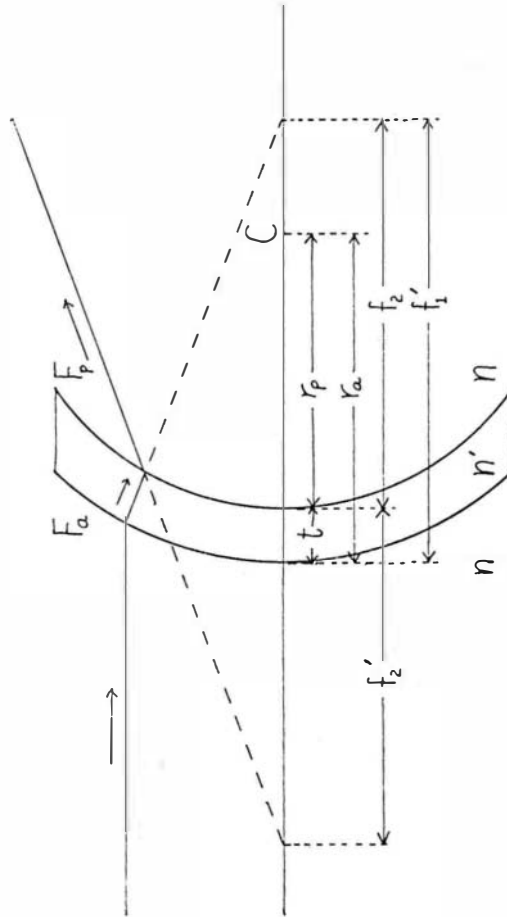

Fig. 3. A ray of light enters the corneal section parallel to the axis, refracted by the section, with the parameters as defined in the discussion, appropriately illustrated.

- $f_1'$  is the focal length after refraction at the first surface,
- $f_2$  is the focal length before refraction at the second surface,
- $F_2$  is the vergency before refraction at the second surface,
- $F_p$  is the dioptric power of the second surface,
- $D_{bs}$  is the dioptric power of the corneal disc, in air, before surgery,
- $n$  is the index of refraction of air,
- $n'$  is the index of refraction of the cornea, and
- $t$  is the thickness of the corneal section.

These six equations may be combined into the following single formula:

$$D_{bs} = \frac{n'(n' - n)}{r_a n' - t(n' - n)} + \frac{n' - n}{r_a - t} \dots\dots\dots (7)$$

Example N<sup>o</sup> 1: K reading: -2.50 cylinder axis 180, axis meridian 42.00. This would mean that the horizontal reading is 42.00 diopters and the vertical reading 44.50 diopters. The mean value in diopters is 43.25, and this corresponds to a radius of 7.80 mm., using the assumed keratometer index of 1.3375.

Example N<sup>o</sup> 2: K reading -2.50 cylinder axis 180, axis meridian 42.00, thickness of corneal disc: 0.4 mm.

$$D_{bs} = \frac{1.376(1.376 - 1.000)}{.0078(1.376) - .0004(1.376 - 1.000)} + \frac{1.000 - 1.376}{.0078 - .0004}$$

$$D_{bs} = 1.921$$

This value for  $D_{bs}$  represents the posterior vertex power of a corneal disc which has been removed from the eye possessing the parameters as stated, assuming, of course, parallelism of the surfaces, and optical homogeneity.

This disc may be placed on a lathe, frozen with the anterior surface in opposition to the lap and have its posterior surface carved to a new radius. For the purpose of optical investigation, however, it is better to make a working assumption that it will be the anterior surface that is carved. In making this assumption, it must be realized that the posterior surface would be frozen to a lap matching in radius the bed of the cornea so that when it is thawed and removed from the lathe, and then sutured back to the eye, the corneal section will not undergo any bending which would, subsequently, change its dioptric power.

AFTER SURGERY

It is now incumbent to discover the dioptric power of the corneal section after its anterior surface is carved. The vertex power may be calculated by the derivation of two final formulae.

Let figure N<sup>o</sup> 4a represent a corneal section after it has been removed from the eye. The shaded areas represent those portions of the sections eliminated by carving. Figure N<sup>o</sup> 4b represents that situation where the carving is to compensate for myopia and figure N<sup>o</sup> 4c represents that situation where the carving is to compensate for hyperopia.

*Myopia*

In myopia, which will be considered first, the area to be carved away represents a convex meniscus lens with a knife edge. Figure N<sup>o</sup> 5<sup>a</sup> demonstrates the following relationship:

$$s_p = s_a - c \dots\dots\dots(8),$$

where:

- c is the thickness of the section to be carved away,
- s<sub>a</sub> is the sagitta of the original mean anterior corneal radius, and
- s<sub>p</sub> is the sagitta of the new mean anterior corneal radius.

The formula for the sagitta of an arc may be derived from figure N<sup>o</sup> 5c by solving right triangles, and is:

$$s = r - \sqrt{r^2 - y^2} \dots\dots\dots(9),$$

where:

y is half the chord of the arc, and represents the semi-diameter of the zone to be carved.

By combining (8) and (9), the following formula is derived:

$$s_p = r_a - \sqrt{r_a^2 - y^2} - C \dots\dots\dots(10),$$

where:

s<sub>p</sub> is the sagitta of the posterior arc and of the new anterior radius.

The formula for the calculation for the radius of an arc may also be derived from figure N<sup>o</sup> 5c by solving right triangles, and is:

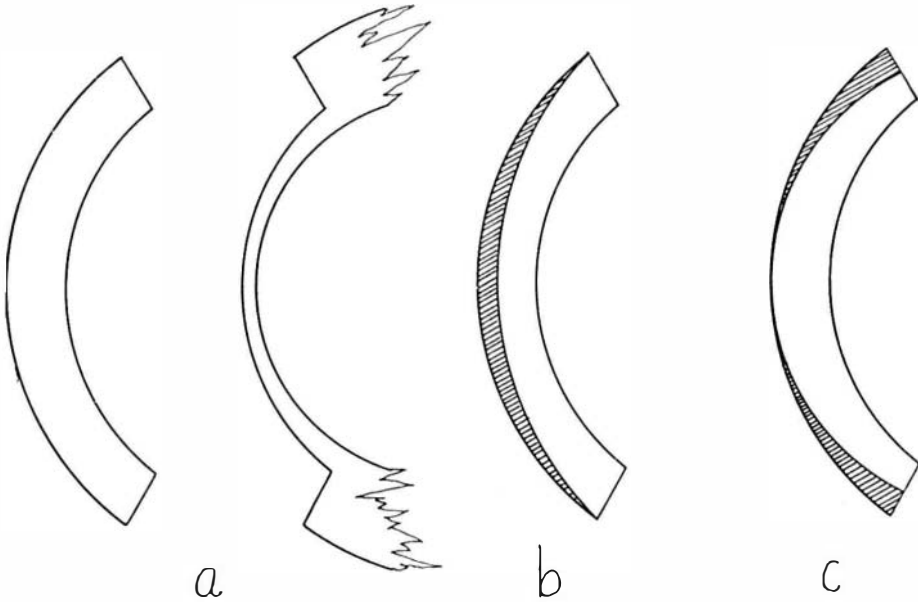

Fig. 4a represents a corneal section removed from the body of the cornea.

Fig. 4b represents the corneal section, the shaded area represents that portion of the cornea to be carved away (schematically but not actually), to correct for myopia.

Fig. 4c represents the corneal section, the shaded area represents that portion of the cornea to be carved away (schematically but not actually), to correct for hyperopia.

$$r = \frac{s^2 + y^2}{2s} \dots\dots\dots (11).$$

Adding subscripts for identification, therefore, in the calculation of the new anterior radius after carving, the following formula is derived:

$$r_{na} = \frac{s_p^2 + y^2}{2s_p} \dots\dots\dots (12),$$

Where

$r_{na}$  is the new anterior radius after carving.

The following formulae may be combined: (10), (12), (1), (2), (3), (4), (5) and (6), with a modification to (6) as follows:

$$D_{as} = F_2 + F_p \dots\dots\dots (13),$$

where:

$D_{as}$  is the dioptric power of the corneal disc after surgery. The combined equation is:

$$D_{as} = \frac{2n's_p(n' - n)}{n'(s_p^2 + y^2) - 2s_p(n' - n)(t - c)} + \frac{n - n'}{r_a - t} \dots\dots\dots (14).$$

### *Hyperopia*

In hyperopia, the area to be carved away represents a concave meniscus lens with a zero center. Figure N<sup>o</sup> 5b demonstrates the following relationship:

$$s_p = s_a + c \dots\dots\dots (15).$$

The following formula is derived by combining (9) and (15):

$$s_p = r_a - \sqrt{r_a^2 - y^2} + c \dots\dots\dots (16).$$

The following formulae may be combined to arrive at the combined equation, representing the dioptric power of the corneal disc after surgery to correct hyperopia: (16), (12), (1), (2), (3), (4), (5) and (13):

$$D_{as} = \frac{2n's_p(n' - n)}{n'(s_p^2 + y^2) - 2s_p t(n' - n)} + \frac{n - n'}{r_a - t}$$

The change in dioptric power from before to after surgery is indicated by the expression:

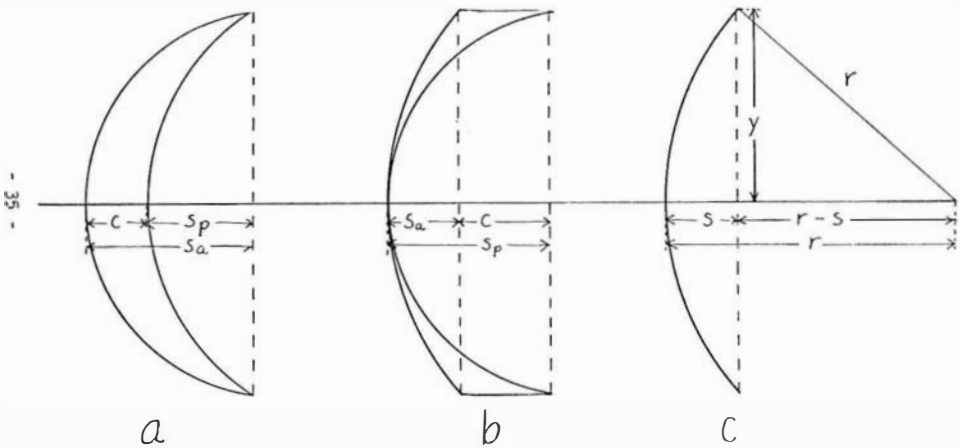

Fig. 5a represents a convex meniscus lens demonstrating the relationship between the sagittae of the anterior and posterior surfaces and the center thickness.

Fig. 5b represents a concave meniscus lens demonstrating the relationship between the sagittae of the anterior and posterior surfaces and the center thickness.

Fig. 5c demonstrates the relationship between an arc's radius, its semi-chord and its sagitta.



$$D_c = D_{as} - D_{bs} \dots\dots\dots (18),$$

where:

$D_c$  is the net change in vertex power of the corneal section, and, consequently, that of the eye, as a result of surgical intervention.

In referring to equations (7), (14) and (17), it may be seen that they each contain two terms, the second of which is identical in all three equations. In (18), therefore, a modification may be made to simplify, in the following manner:

$$D_c = D_{as} \text{ (first term)} - D_{bs} \text{ (first term)} \dots\dots\dots (19)$$

### DERIVATION OF TABLES

Rather than laboriously calculate for each operation, tables may be calculated for the value  $D_c$ . The number of variables that might be used in the calculation of tables may be examined at this point. The normal limits of corneal radius measurement may be taken as the limits of the Bausch & Lomb keratometer, for instance. This ranges from 36.00 diopters at the flattest to 52.00 diopters at the steepest. Therefore, at increments of 0.25 diopters, there would be 64 values for  $r$ . The usual maximum and minimum limits of the area to be carved are 6 and 8 mm. diameter circles. Proceeding in increments of 0.25 mm., a total of 9 values could be substituted for  $y$ . The maximum thickness consistent with surgical considerations, may be taken to be 0.4 mm. for the corneal disc before carving. The maximum reduction in either center or edge thickness is considered to be 0.28 mm. leaving 0.12 mm. at the thinnest point of the section after carving. Proceeding in increments of 0.01 mm., a total of 28 values may be substituted for  $c$ . Therefore, tables would have to be calculated which would contain more than 30,00 answers. In order to avoid this task, short cuts were evolved without materially affecting the outcome.

#### *Linearity of "c"*

The linearity of the value "c" was tested in the following manner: values were assigned for the different variables and the net change in vertex power was calculated, using different values for  $c$  in a number of calculations. The first calculation will be explained and the others will follow:

Example N<sup>o</sup> 3: A corneal section with the following dimensions is carved in such a manner as to reduce its center thickness by 0.01 mm. in order to correct myopia:

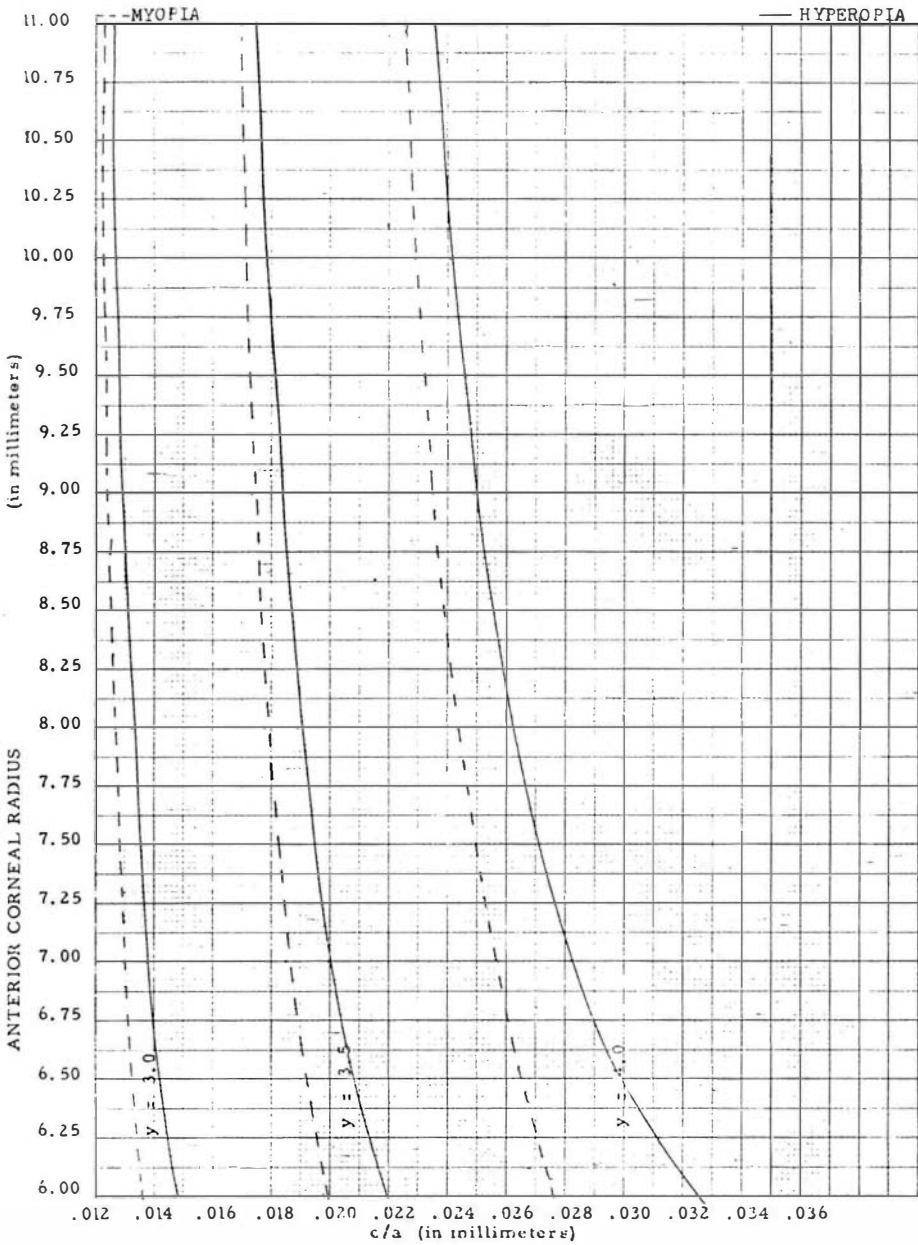

Fig. 6. A graph demonstrating the relationship between the mean anterior corneal radius and the c/a value. This graph reflects the information in table N<sup>o</sup> 3.

## CALCULATION SCHEMA

1. Net Static Retinoscopy: O.D.	
O.S.	
2. K Readings : O.D.	
O.S.	
3. Mean Corneal Curvatures:	
4. Y Value:	
5. Determination of c/a value (from the graph):	
6. Mean Correction:	
7. Determination of c (multiplication of the c/a value by the ametropia):	
8. Determination of $s_a$ (by using the datum of the mean corneal radius and y with the sagitta tables):	
9. Determination of $s_p$ ( $s_p = s_a - c$ in myopia, and $s_p = s_a + c$ in hyperopia):	
10. Determination of the new anterior radius (by using the datum of $s_p$ with the sagitta tables):	
11. Original Thickness of Corneal Disc:	
12. Determination of the new posterior radius (deduct original thickness of corneal disc from original mean anterior corneal radius:	

Fig. 7. The form used by the Katzin group for biological experimentation to calculate the values necessary for the appropriate lathe-settings and the choice of lap for the carving of the corneal section.

original mean radius (K reading mean):	11.066 mm.,
diameter of portion to be carved (2y):	4.0 mm.,
thickness before carving	: 0.4 mm.,
relationship of surfaces	: parallelism.

The results of the calculation follow:

vertex power of the section before carving	: -0.935
vertex power of the section after carving	: -1.386
net change in vertex power as a result of carving:	-0.451

The same calculations were made with different  $c$  values and the resultant net changes are shown in table N<sup>o</sup> 1.

It may be seen that each additional reduction in center thickness, there is an additional increment in the increase in change.

It may be seen, in the last column, that the change of -13.490 diopters as a result of 0.30 reduction in center thickness averages 0.449 for each increment of 0.01 mm. change in center thickness. If the assumption of  $c$ 's linearity is made, therefore, the range of error in calculation is plus or minus 0.004 diopters in the resultant calculation. It was assumed, therefore, that the value for  $c$  may be considered lineal for the purposes of the calculations for this procedure.

#### *Effect of Thickness Reduction*

A number of calculations were made, all of which used an assumed value for  $c$  of 0.1 mm. These calculations used three different  $y$  values: 3.0 mm., 3.5 mm. and 4.0 mm. They also used six different assumed radii of curvature from 6.00 mm. through 11.00 mm., at increments of 1.00 mm. The calculations were made for both myopia and hyperopia (table N<sup>o</sup> 2).

Each of the calculations yielded the following information: if the center or edge thickness was reduced 0.1 mm., with the particular  $y$  and the particular  $r$  that was assumed the net change in vertex power was determined. The results of this series of calculations appear in table N<sup>o</sup> 2.

#### *Derivation of Graphs*

Any of the resultant calculations may be selected to illustrate the next principle. The calculation for the net change in vergency for a cornea of mean radius of 6.00 mm., with a  $y$  value of 3.0 mm., is equal to 7.406 diopters, according to

## REFRACTIVE KERATOPLASTY

TABLE I

Calculation of the increments in changing power by increasing the c value.

c value	:	0.010	0.020	0.030	0.040	0.050	0.300
D <sub>as</sub>	:	-1.386	-1.827	-2.269	-2.712	-3.155	-14.425
D <sub>bs</sub>	:	-0.935	-0.935	-0.935	-0.935	-0.935	-0.935
net change	:	-0.451	-0.892	-1.334	-1.777	-2.220	-13.490
minus previous net change:			-0.451	-0.892	-1.334	-1.777	÷ 30
increment			0.441	0.442	0.443	0.443	0.447

TABLE II

Calculation for net change in power of corneal disc of thickness 0.4 mm. by reducing center or edge thickness 0.1 mm. with different y values.

## EDGE REDUCTION - CORRECTION OF HYPEROPIA

	original mean anterior corneal radius					
y	6.000	7.000	8.000	9.000	10.000	11.000
3.0	6.826	7.257	7.534	7.718	7.841	7.945
3.5	4.565	5.008	5.289	5.470	5.604	5.726
4.0	3.083	3.546	3.830	4.021	4.158	4.254

## CENTER REDUCTION - CORRECTION OF MYOPIA

	original mean anterior corneal radius					
y	6.000	7.000	8.000	9.000	10.000	11.000
3.0	7.406	7.720	7.910	8.036	8.129	8.153
3.5	5.058	5.401	5.620	5.755	5.848	5.890
4.0	3.525	3.890	4.113	4.261	4.363	4.435

table N<sup>o</sup> 2. This would mean that a 0.1 mm. reduction in center thickness would cause a change in vertex power of 7.406 diopters. If this  $c$  value of 0.1 mm. is divided by the ametropia of -7.406 diopters, the resultant amount is .0135. Therefore the relationship of  $c/a$  may be calculated by determining the reciprocal of each of the values in table N<sup>o</sup> 2. The  $c/a$  values are listed in table N<sup>o</sup> 3. These values may be plotted in graph form. Figure N<sup>o</sup> 6 is the graph containing the information in table N<sup>o</sup> 3. The graph may be utilized for smaller increments of radius than those used for the calculations. The ordinate is the K reading in millimeters of radius and the abscissa is the  $c/a$  value.

The graph may be applied in the following manner: The appropriate  $y$  value is selected, based on considerations that will be described in a later section of this discussion. The mean corneal radius is found on the graph, and the intersection of this line with the curve on the graph is the  $c/a$  value. Once the  $c/a$  value is determined, it is multiplied by the ametropia to arrive at  $c$ , since  $c/a \cdot a = c$ . This is the method used to determine the degree of ametropia.

Example N<sup>o</sup> 4: K reading: -2.50 cylinder axis 180, axis meridian 42.00. 5.00 diopters myopia.

mean corneal radius	:	7.80
$y$ value	:	3 mm.
$c/a$ (from graph)	:	0.01271
$c/a \cdot a = c$	:	0.06355

Therefore, in this hypothetical situation, there would be a reduction of 0.06355 mm. in the central thickness in a carved zone of 6 mm. in diameter in order to achieve a correction of the myopia.

All this reasoning has been predicated upon carving the anterior surface of the cornea. This approach, from a surgical standpoint, is unwise, since it would involve the carving of Bowmans membrane. It is necessary to carve the posterior surface of the corneal disc. This brings to the fore the mathematical danger of reducing center thickness without taking the radius of carving into consideration. If the appropriate change in center thickness is carved in the posterior surface and the corneal section is later bent to the curvature of the bed before suturing, the vertex power of the section will change as a consequence of bending<sup>5</sup>. Therefore, the corneal section must be frozen in opposition to the concave lap so that the anterior surface will assume the final curvature desired after it is placed in the bed. Now, if the front curvature will match the final curvature desired, so will the posterior curvature, after carving to match the curvature of the bed.

## REFRACTIVE KERATOPLASTY

TABLE III

c/a Values

## EDGE REDUCTION - CORRECTION OF HYPEROPIA

	y	original mean anterior corneal radius				
		6.0	7.0	8.0	9.0	10.0
3.0	0.01465	0.01378	0.01327	0.01296	0.01275	0.01259
3.5	0.02191	0.01997	0.01891	0.01830	0.01784	0.01746
4.0	0.03244	0.02820	0.02611	0.02487	0.02405	0.02351

## CENTER REDUCTION - CORRECTION OF MYOPIA

	y	original mean anterior corneal radius				
		6.0	7.0	8.0	9.0	10.0
3.0	0.01350	0.01295	0.01264	0.01244	0.01230	0.01227
3.5	0.01997	0.01853	0.01779	0.01738	0.01710	0.01698
4.0	0.02759	0.02571	0.02431	0.02347	0.02292	0.02255

TABLE IV

*Theoretical Limits of Dioptric Change by Carving  
Edge Reduction - Correction of Hyperopia*

y	original mean anterior cornea! radius					
	6.000	7.000	8.000	9.000	10.000	11.000
3.	19.113	20.320	21.095	21.610	21.955	22.246
3.5	12.782	14.022	14.809	15.316	15.691	16.033
4.0	8.632	9.929	10.724	11.259	11.642	11.911

## CENTER REDUCTION - CORRECTION OF MYOPIA

y	original mean anterior cornea! radius					
	6.000	7.000	8.000	9.000	10.000	11.000
3.0	20.737	21.616	22.148	22.501	22.761	22.828
3.5	14.162	15.123	15.736	16.114	16.374	16.492
4.0	9.870	10.892	11.516	11.931	12.216	12.418

The curvature of the bed is known. It is calculated simply by subtracting the thickness of the corneal disc from the mean anterior corneal radius.

Example N<sup>o</sup> 5: mean anterior corneal radius: 7.80 mm., thickness of corneal section: 0.4 mm., mean radius of bed  $7.80 - 0.40 = 7.40$  mm.

If the anterior surface of the cornea, therefore, were bent to a concave lap precalculated in radius to be the desired radius after surgery, it is then merely necessary to carve the corneal bed radius into the posterior surface of the corneal slice.

It is now incumbent to determine the new anterior corneal radius. This may be performed in the following manner:

1. determine the sagitta of the original mean anterior corneal radius (by the application of formula (9) or consulting tables).
2. subtract the c value as previously determined in myopia, or add the c value as previously determined in hyperopia; this result is the sagitta for the new anterior corneal radius (the application of formula (8) or (15) ), and
3. determine the new anterior corneal radius from the data of the sagitta and the y value (by the application of formula (1) or consulting tables).

There are sagitta tables computed expressly for this purpose. Barraquer <sup>6</sup> has published a series but the most comprehensive tables are by Creighton <sup>7</sup>. The utilization of Creighton's tables enables one to easily translate radius to the corresponding sagitta, given a y value, and vice versa.

## OPTICAL LIMITS

It would be interesting to determine the theoretical limits of dioptric change by carving. This may be performed by consulting table N<sup>o</sup> 4. The first figure that appears on the table may be used as an illustration.

Example N<sup>o</sup> 6: for a cornea with a mean anterior radius of 6.00 m., and for a preselected y value of 3.0 mm., it may be seen that a 0.1 mm. reduction in edge thickness would yield a change of 6.826 diopiers. This edge thickness change would be desired in the correction of hyperopia. Since the maximum degree of thickness change dictated by surgical considerations is 0.28 mm., the multiplication of 2.8 by the degree of change wrought by 0.1 mm., reduction in thickness would yield the maximum dioptric change possible. It may be seen, therefore, that in the example as described, the maximum change possible with an original mean corneal radius of 6.00 mm. and a y value of 3.0 mm. is 19.113 diopters.



Inspection of table N<sup>o</sup> 4 will reveal that the smaller the  $y$  value, the greater the maximum change possible. Also, the flatter the original mean anterior corneal radius, the greater the degree of maximum change possible. Also, assuming the same  $y$  value and the same original anterior corneal radius, it may be seen that the maximum change possible is greater in myopia correction than is hyperopia correction.

### SELECTION OF THE APPROPRIATE “ $y$ ”

Selection of the appropriate  $y$  value has been cursorily mentioned but passed over. It is now germane to discuss the considerations that inter into the selection of the appropriate  $y$  value. The two main factors to be evaluated are the original ametropia of the eye, and the thickness of the corneal disc after carving. It has also been mentioned that surgical considerations dictate that the minimum remaining corneal disc thickness should not be less than 0.12 mm. The maximum permissible  $c$  value, therefore, must be 0.28 mm., assuming an original corneal disc thickness of 0.4 mm. If the original corneal disc thickness is greater or less than 0.4 mm., the value of 0.12 mm. is merely deducted from this to arrive at the maximum permissible  $c$  value (this being the reduction in center or edge thickness necessary to achieve the desired results).

Table N<sup>o</sup> 4 reveals that the original mean anterior corneal radius and the  $y$  value are the factors that limit the maximum change in the correction of the ametropia. If a larger  $y$  value is chosen, the accuracy of the carving will be greater. However, if the desired correction cannot be achieved with this larger  $y$  value, a smaller one must be chosen. Table N<sup>o</sup> 4, therefore, must be examined in order to compare the ametropia and the original mean anterior corneal radius, maximum change possible with the ametropia in the particular case under consideration. If the maximum change possible is less than the ametropia to be corrected using a larger  $y$  value, it is then necessary to select the next smaller  $y$  value in order to achieve the desired change.

### CONCLUSION

Any method of calculation that envisages lathe-carving the corneal section followed by bending the carved section to a different curvature must, of necessity, take in to consideration the consequences of dioptric change as a result of bending. The degree of this change is not accurately predictable. It is submitted, therefore, that the most accurate approach in the solution of this problem is one where the corneal section is bent before carving, so that the anterior surface will

conform to its desired new curvature. This will allow the lathe-carving of the posterior surface to a curvature matching that of the bed, so that no further bending will take place after carving. The pitfall of dioptric change as a consequence of bending will then be avoided.

### SUMMARY

The best summary of the steps necessary in the calculation of the parameters necessary in the calculation of the parameters for lathe carving the corneal disc in refractive keratoplasty may be had by referring to figure N<sup>o</sup> 7. This is a form used by the Katzin group in the biological experimentation phase of their refractive keratoplasty research. The appropriate lap may then be chosen and the lathe correctly set to carve the frozen corneal section so that the desired result will be achieved.

### ABSTRACT

Refractive keratoplasty is a form of surgical intervention which has been devised to alter the cornea so as to eliminate ametropia.

The eye is fixed with a pneumatic ring through which passes a microkeratome. This instrument, which operates on the principle of a carpenter's plane, shaves a corneal disc from the eye. The disc is then carved and replaced on its bed.

This paper contains some introductory background, relating to technique, but is principally devoted to the formulation of change by lathe-carving the corneal tissue disc. The anterior surface of the corneal disc is frozen to a concave lap, precalculated to match the desired new anterior radius of the cornea. The posterior surface is carved to match the radius of the corneal bed. The optical considerations and calculations for this method are explained.

New York . 210 East  
Sixty-fourth Street.

## REFRACTIVE KERATOPLASTY

### BIBLIOGRAPHY

1. BARRAQUER JOSE I., Fundamentals of Refractive Keratoplasty, first draft, in preparation for publication.
2. BARRAQUER, JOSE I., Queratomileusis para la Corrección de la Miopía, Arch. Soc. Amer. Oftal, optom., 5, 27, 1964.
3. BARRAQUER JOSE I., Cálculo Queratomileusis para la Corrección de la Miopía Técnica, Arch. Soc. Amer. Oftal-Optom., March 1, 1965.
4. MARTINEZ, MIGUEL and KATZIN, HERBERT M., Refractive Keratoplasty, The Cornea World Congress, Butterworths, Washington, 1965, pp. 605-616.
5. KATZIN, HERBERT M., Optical Considerations of Refractive Keratoplasty, final draft in preparation for publication.
6. KAPLAN, MILTON M., Optical Considerations of Hydrophilic Lenses, The Optometrick Weekly, accepted for publication.
7. CREIGHTON, CARLES PATRICK, Contact Lenses' Fabrication Tables, John R. Creighton, Tonawanda, New York, 1964.

## A TECHNIQUE FOR DIAGNOSTIC CONTACT LENS FITTING

BY

JOHN R. KENNEDY O. D.

St. Paul - U.S.A.

The beginning of the new often comes from the ending of the old. From past experience and knowledge we can arrive at premises and procedures which would otherwise be impossible. So if you have chosen the contact lens field as your challenge and endeavor then your beginning must be made and those of us who have gone before can each help a little.

It is recognized that the large, successful contact lens practices in the United States, as in other parts of the world are concentrated in the offices of a few men. There are many practitioners who do contact lens work, but by and large it is limited and a small part of their general eye care practice. It will be the intent of this paper to draw from the knowledge and experiences in my travels and practice to present a procedure to help the small contact lens practitioner or the man who is about to enter this field. We are all impressed by the fine and valuable contributions that have been made in the contact lens field by research and by manufacturers, by the remarkable developments in plastics and the fabrication thereof, by the pharmaceutical developments and the excellent supportive products we now have from the field of chemistry and by the theoretical conceptions which have evolved into procedures and techniques that are very much a part of the general practice of contact lens fitting.

The road to success in contact lens fitting is the elaborate road, not the make-shift one. The best equipment is the easiest to use. The finest instruments are the simplest and the most accurate. Certain basic mechanical and optical equipment is essential and the very minimum is as follows:

- 1) Radiuscope

- 2) High quality thickness gauge — stand mounted
- 3) Lensometer
- 4) Diameter measure scale
- 5) Seven power magnifier for optical zone measurement
- 6) Lens thickness charts
- 7) Ophthalmometer
- 8) Millimeter-diopter conversion charts or slide rule.

These above instruments are relatively expensive, but your practice grows in direct proportion to the success of your patients. The sooner you have this equipment and the better that it is, the sooner you will have positive control of your fitting. So, obtain them as promptly as you can and you will thank yourself every day. I could not work one day without a Radiuscope type instrument.

*Compared to what?* When the experienced fitter puts a diagnostic lens on a patient's eye, he can often write out the formula for a successful lens at that moment. He uses his scientifically gathered findings just as the new fitter does, but when he looks at a lens on a patient's eye he then uses something the new fitter does not have. "The background of many successful cases and the knowledge of what constitutes a proper fit". He compares this lens to known standards which he carries in his computer brain.

The new fitter compares the lens to nothing except theory and knowledge. It is great, but not enough so to hasten the day when the new fitter becomes experienced. This paper suggests a two or more diagnostic lens comparative technique in which two different designs are compared simultaneous one on each eye.

*Time for decision.* The time of decision for the contact lens fitter comes after he has gathered all necessary data from and about the patient including the eye findings. He must now decide what lens will be "designed" for this patient. Will it be large or small? Will it be steep, parallel, or flat? Will it be thick or thin? The questions are multitudinous, but the decision *must* be made at this point. Here, I concur with many other writers that the easiest and most successful way to arrive at this decision is through the use of diagnostic contact lenses. The diagnostic contact lens must be as precisely close to your finally prescribed contact lens as your physical equipment and mental capabilities will permit. If an adequate diagnostic trial set of lenses is not part of your office equipment then the relatively new contact lens fitter should strongly consider the use of case basis fitting (lens ordering system where laboratory provides as many lenses as needed to arrive at final best design) or the method in your

area that enables you to have a number of lenses to see upon the patient's eye before making a decision.

I suggest you consider at least two different lens designs on each patient. The least expensive and the most informative way to do this is to have a different design for each eye or two different designs for one eye.

The one for the right eye could be Design "A", which I will explain shortly, the one for the left eye could be Design "B". I will be rather precise in describing these designs knowing that as the fitter's experience expands he will promptly modify techniques in the direction of more successful fitting and more delicate procedure. I cannot tell you in your country exactly what lens to use on the patient you have before you, but having taught contact lens procedure to many students, I know we must proceed from the simple to the complex. So, some leniency is taken in this paper to over-simplify the fitting procedures, trusting my reader is seriously dedicated and adequately schooled to bring his foundational knowledge to the fore in arriving at proper lens design. The two lens formulas that we may consider are not arbitrarily chosen, the first is a basic author design which has been used and proven over more than fifteen years and can be depended upon as a reliable beginning formula. So let us assume that for lens "A" for the right eye we begin with a lens which is .02 mm. of radius longer curvature than the longest meridian of the patient's cornea measured on a very good and precise ophthalmometer. The secondary (intermediate) curve will be 2 diopters flatter than the base curve. The diameter of the lens, 9.7 mm. The peripheral curve, .3 mm. on a 12.25 tool. The optical zone, 7.6 mm, and the thickness will be .008 inches (.02 M/M) if the power is approximately -2.50, thinner for more minus, thicker for less minus. The contact lens "B" formula will be as follows: Base curve, 1.25 diopters steeper than the longest meridian of corneal K, reading. Secondary curve (intermediate) 2 diopters flatter than the K reading. Note it is 2 diopters flatter than cornea "K", not lens-base curve. Diameter, 8.2 mm. Thickness, .006 if the dioptric power is approximately -3.00 thinner if more minus, thicker if less minus (refer to laboratory thickness chart) Optical zone, 6.6 mm. Peripheral curve (bevel) .1 on a 17.00 diopter tool and power -1.25 more minus than patients R/x for corrective ophthalmic lens.

Now these two lenses will bracket several current philosophies of fitting and with reasonable judgment on your part, should enable you to arrive at a successful pair of contact lenses for your patient. In both of these lenses the power was to have been computed to be optically correct for the patient for best V. A. You should evaluate the fluorescein fit of the contact lenses, the tear flow, the positioning of the lens, the injection or absence of injection of the scleral conjunctiva, the subjective symptoms and your objective opinion of the fit of these lenses. You can now compare one lens to something instead of nothing and

quickly your judgment will develop. Remove one lens if there seems to be a problem and continue to observe the performance of the other lens. The whole procedure can be completed in a short time, but with periodic observations on the part of the doctor.

A very important word of caution: If both lenses are applied at the same time, A in the right eye, B in the left eye, the patient will report the left smaller lens more irritating. Therefore, have the patient wear the smaller lens only for ten to twenty minutes before applying the larger lens. It is extremely important in our field to be objective and open-minded because there exists extreme rigidity of opinion among many practitioners and they prefer to protect their ideas of fitting to the exclusion of progress. We are constantly learning and must constantly adjust and adapt to better procedures.

In no event should a final opinion be reached in less than three hours patients wear and then only after your critical observation. Make your decision which of the two designs you prefer? How must you modify or change the design to arrive at the best one for your patient? And at this point, if your judgment was very good, it will be necessary to make only one more lens. If your judgment was somewhat naive and lacking in experience, it may be very necessary and desirable to make a new pair of lenses based on the information and data you gained from the comparative diagnostic fitting.

As I stated earlier, I am in favor of diagnostic trial lens sets. We have an extensive number in our two offices, but we almost never have just the one that we want. For this reason, I remind you that your best diagnostic lens is the first contact lens you actually order for the patient. This has the proper weight, size, thickness, diameter, power and curvature. You must see it on the eye and then record in your history the best contact for each eye —not the formula of the one diagnostic he is wearing, but how you would alter that diagnostic lens for the perfect lens. Record it even if only slightly different from the one observed. This will be your basic lens design. Future alterations will relate to it.

I believe your laboratory should welcome the opportunity for you to have several lenses in your possession on each patient in the beginning rather than one pair at a time because it will hasten the day of mature judgment when it will only be necessary for you to have one pair of lenses in your possession for each patient.

*IS THIS ALL?* A brief critique on the above techniques is very much indicated. Contact lens fitting is an art and a science. Some men by their nature, training and background can and will become successful practitioners in the micro-miniature area of corneal contact lenses. Certain other men will never learn the art and the skill of fitting contact lenses, and a "misfit" in the contact

## CONTACT LENS

lens field will misfit continually to the detriment of all for years to come. The great majority will do moderately well with contact lens fitting in their practice. In my opinion, it is still a specialty, and one of the most challenging in the world today. It is almost possible to relate a man's philosophy to his success or lack thereof in the contact lens field. The great fitters that I have met in South and Central America, in Europe, England and Scandinavia, and in the great United States, were each and every one a highly dedicated practitioner relatively sensitive of personality and gifted with a desire for constant knowledge and improvement. To you, the new contact lens fitter, I give this thought: After making your decision and fitting the best pair of lenses for your patient, and when you have applied your skill to the fitting of these lenses and the proper training of the patient, if symptomatology develops, please consult with the most experienced practitioner in your area. This is the time in contact lens fitting when personal discussion with another practitioner is most valuable. Discuss the fitting and the problem of your patient, it is very likely he can help you over those initial problems that must be solved before you become captain of your own contact lens destiny.

451 Lowry Medical Arts  
St. Paul, Minnesota

## REFERENCES

- <sup>1</sup> Baldwin, William and Chos, Shick, "Corneal Contact Lens Fitting Procedure, "Philadelphia-New York Chilton Company, 1962.
- <sup>2</sup> Grosvenor, T.P., "Contact Lens Theory and Practice, "Professional Press, 1963.
- <sup>3</sup> Moudell, R. B., "Contact Lens Practice-Basic and Advance", Charles C. Thomas, 1965.
- <sup>4</sup> Schnider, Harold A., O.D., "Role of the Contact Lens Diameter", *Contacto*, Special Edition, March ,1967.
- <sup>5</sup> Sloan, David P., Jr., O.D., "Small Lens Fitting", *Contacto*, Special Edition, March, 1967.



## NON-OCULAR MANIFESTATION OF SYMPATHETIC OPHTHALMIA

BY

S. R. K MALIK, M.D., A. K. GUPTA, M.D., GURBAX SINGH, M.D.

New Delhi, India.

Sympathetic ophthalmia is a bilateral granulomatous uveitis usually resulting from perforating injury of the eye especially involving the ciliary body and the root of the iris. In most of the cases, it is believed that the clinical manifestations remain confined to the eye alone. In few cases, however, certain general signs symptoms like vitiligo, poliosis, alopecia, dysacusia and meningeal irritation may be encountered. (DukeElder 1939; Cowper 1951; Swartz 1955; Walsh 1956; Wilson 1962; and Sorsby 1964). The latter manifestations are a constant feature in Vogt Koyanagi Harada's Syndrome. Due to this, there has been a temptation to group Sympathetic ophthalmia, Vogt-Koyanagi and Harada's disease in a common category of uveo-meningeal or Uveo encephalitic syndrome. (Cowper 1951; Swartz 1955; Wilson 1962 and Sorsby 1964).

The aim of present communication is to stress the importance of non-ocular manifestations of sympathetic ophthalmia in 10 cases seen in Irwin Hospital, New Delhi from 1963 to 1967.

**OBSERVATIONS:** Out of 10 cases of Sympathetic ophthalmia observed, one or more of the following non-ocular features were present in every case. (Table 1 & 2).

I. *Meningism*: Its incidence was 80%. It was characterised by headache, nausea, severe periorbital pain, hyperirritability, and psychic disturbances. These symptoms appeared concomitant with the onset of uveitis.

II. *Dysacusia and Deafness*: It was seen in 9 cases (90%). The presentation was in the form of tinnitus and partial deafness. On audiometry, it was

TABLE 1

*Incidence of non-ocular Manifestations in 10 cases.*

<i>Signs</i>	<i>Cases</i>	<i>Percentage</i>
Meningism	8	80%
Dysacusia & deafness	9	90%
Vitiligo, Poliosis	2	20%

found to be perceptive type of deafness. Auditory symptoms developed simultaneously with the onset of uveitis.

III. *Pigmentary Disturbances:* Vitiligo, poliosis, were seen in 2 cases (20%). This appeared 12 weeks after the onset of the uveitis.

## DISCUSSION

Existence of sympathetic ophthalmia has been recognised for hundreds of years, but the term sympathetic ophthalmia was only coined in 1835 by Mackenzie who gave an accurate description of the condition and reached few conclusions which are even accepted at present. Rarely sympathetic ophthalmia has been described to be associated with certain non-ocular symptoms e. g. meningism, dysacusia, and dermal manifestations. These non-ocular manifestations are a constant feature either singly or in combination with Vogt-Koyanagi-Harada Syndrome. (DukeElder 1939; Walsh 1956 and Sorsby 1964).

Because of the common modes of manifestation of the sympathetic ophthalmitis and Vogt-Koyanagi Harada disease, these conditions have been grouped under one heading of uveo-meningeal syndromes (Cowper 1951; Swartz 1955; Walsh 1956; Wilson 1962 & Sorsby 1964).

Our observations, however, in cases of sympathetic ophthalmitis reveal that the incidence of non-ocular manifestations is significantly high, provided we carefully look for these manifestations. The dysacusia was the commonest association and was seen in 90% of the cases. Next commonest was the meningism which was seen in 80% of the cases. Vitiligo and Poliosis was seen in only 20%

SYMPATHETIC OPHTHALMIA

of the cases. On the basis of our experience from these cases we strangely feel and suggest that audiometry should be done in each case of sympathetic ophthalmia.

TABLE 11

*Order of appearance of Non-ocular Manifestation  
in relation to onset of Uveitis.*

<i>Signs</i>	<i>Before Uveitis</i>	<i>With Uveitis</i>	<i>After 12 weeks of Uveitis</i>
<b>Meningism</b>	—	8 cases	—
<b>Dysacusia</b>	—	9 cases	—
<b>Vitiligo &amp; Poliosis</b>	—	—	2
<b>Alopacea</b>	—	—	—

The recognition of these manifestations in sympathetic ophthalmitis is important not only from the academic point of view but pose a great problem in the management of these cases. The acute manifestations of meningism might disappear in a few weeks time, but certain vague complaints in the form of heaviness of that head, headache, periorbital pain may persist even for few months after the uveitis has come under control. Similarly, dysacusia and tinnitus may leave the patient permanently handicapped inspite of good visual improvement. Two of our cases have to put on hearing aids.

The Auro-dermal manifestation of the uveomaningeal syndrome have been explained on either the hypothesis of the existance of a melanophoric virus or on the development of hypersensitivity to uveal pigment.

SUMMARY AND CONCLUSION:

- (I) Non-ocular symptoms and signs in 10 cases of sympathetic ophthalmia are presented.
- (II) Dysacusia in 90%; meningism in 80%; Pigmentary disturbances in 20% patients were encountered.
- (III) Meningism and dysacusia appeared synchronous with uveitis while pigmentary disturbances appeared relatively late after the onset of uveitis.
- (IV) It has been stressed that the non-ocular signs and symptoms in sympathetic ophthalmia are seen frequently if carefully looked for and pose a great problem in the final management of these cases.

REFERENCES:

1. COWPER, A. R. (1951). A. M. A. Arch. Ophthal. 45, 367.
2. DUKE ELDER (1939) - Text Book of Ophthalmology. Henrykimpton, London, Vol. III, pp. 23-24.
3. HAGER, G. (1957). KLIN, M.bl. Augh. 115, 333.
4. SWARTZ, E. A. (1955). Amer. J. Ophthalmology. 39, 488.
5. SORSBY, A. Modern Ophthalmology London, Butterworths, 1964, V. 4.
6. SORSBY, A. Modern Ophthalmology London, Butterworths, 1964, V. 3. Page 442.
7. WILSON, P.: Sympathetic ophthalmatis simulating. Harada disease. Brit. J. Ophthal. Vol. 46, Page 626, 1962.

G. B. Pant. Hospital

## UN SYNDROME d' ALPORT?

PAR

JAIME SOLARES-ZAMORA

Cochabamba, Bolivia

L'association de troubles rénales, auditives et oculaires, désignée en 1961 par Williamson sous le nom de "Syndrome d'Alport", est un ensemble, pas fréquent parmi les néphropathies familiales (pas plus de 50 cas publiés dans la littérature médicale).

Avant de décrire le cas que nous allons présenter nous ferons une révision assez rapide des principaux caractères du syndrome. A tous ceux qu'intéressera approfondir l'étude de ce thème nous suggérons la lecture des travaux d'Alport, Perkoff, Sohar, Reyersbach, Buttler, Goldbloom, Mettier, Perrin, Gregg et Becker, etc.

*Néphropathie.* — De type familiale, il semble s'agir génétiquement d'une transmission intermédiaire liée au sexe. Les hommes en sont atteints comme une forme complète (pour porter un seul chromosome x), tandis que les femmes en souffrent, sous une forme atténuée (conséquence de la modification ou atténuation exercée par le chromosome x normal sur le chromosome x pathologique).

Il s'agit d'une glomérulonéphrite généralement grave, à évolution variable, qui très souvent produit la mort avant l'âge de 30 ans. L'examen clinique décèle les symptômes, parfois atténués, d'une glomérulonéphrite, pouvant, dans un parcours plus ou moins éloigné s'associer à une infection (pyélonéphrite). Souvent il n'y a pas de compromis général d'ordre vasculaire. L'examen radiologique ne décèle de troubles morphologiques ni fonctionnels. L'analyse d'urines montre une albuminurie, une hématurie et parfois une bactériurie.

*Surdité.* — A ce qu'il semble, précoce dans son apparition; souvent elle n'est pas progressive. Il s'agit d'une surdité de perception pure, bilatérale, symétrique, sans recrutement.

*Atteinte oculaire.* — Les troubles oculaires sont assez nombreux, mais la plupart de ceux-ci atteignent le cristallin; cet organe-ci vient être, comme bien le dit Perrin, la “vedette” de la pathologie oculaire du syndrome. Parmi ces troubles, tels que cataracte polaire antérieure, cataracte sous-capsulaire antérieure ou postérieure, micro-sphérophakie, lenticône antérieur, postérieur, ou mixte, avec épaissement kératique, il nous semble que ces derniers (lenticônes), soient les plus fréquents.

Quoique très souvent la découverte de ces troubles soit tardive, ils existent sûrement depuis la naissance. Perrin soutient qu'ils ne sont pas évolutifs; cependant, le cas que nous avons observé eut une évolution progressive manifeste, et l'on peut aussi penser que c'était, envers le cas de Gregg et Becker, dont on peut présumer que la rupture spontanée du cristallin aurait été due à une progression de la lésion de la lentille.

D'autres troubles oculaires discrets, comme opacités cornéennes, cataractes poussiéreuses ou punctiformes peuvent signifier formes frustes ou peu notoires, équivalentes de l'atteinte oculaire du syndrome chez quelques personnes de la famille dont existait un cas évident (Perrin).

Le cas que l'on va présenter joint à l'intérêt de sa propre nature, le fait qu'il pose la possibilité d'ouvrir une discussion, car ses caractéristiques l'encadrent comme un syndrome d'Alport, quoique certaines circonstances, notées parmi quelques uns des symptômes, poussent à méditer sur sa valeur et son authenticité comme composantes de la triade du syndrome sus-indiqué.

#### *Observation personnelle.*

Cas clinique N<sup>o</sup> 174/61. - G. B. M. - Âge 10 ans. - métis; écolier. - Est amené à la consultation parce que sa vision diminue depuis un peu plus d'un mois.

*Antécédents familiaux.* Au premier interrogatoire, l'on ne trouve rien d'important. - Mère, grossesse normale, accouchement eutocique.

*Antécédents pathologiques.* Amygdalite chronique depuis l'âge de 4 ans, poussées graves; après amygdalectomie, sans suites. Parésie légère, qui ne dura pas longtemps, des membres inférieurs, comme séquelle de rougeole. Surdité depuis qu'il était encore petit, mais que le père attribue à l'emploi prolongé de streptomycine.

*Examen ophtalmologique.* Aux deux yeux: conjonctives normales. Cornées avec des opacités petites et tenues dans la Descemet, quelques unes avec un aspect de petites bulles d'air au centre de la cornée. Chambre antérieure de profondeur et contenu normale. Cristallin: lenticône antérieur discret, à l'O.D., et un peu plus prononcé à l'O.G.; cristalloïde d'aspect normal, sauf opacités centrales

#### SYNDROME D' ALPORT

très fines; reste du cristallin normal. Iris, pupille et ses réflexes, normaux. Tension oculaire (aplanation), O.D., 10 mm. et O.G. 11 mm. Fond des yeux normal  
Motilité extrinsèque normale.

La skiascopie faite sous cycloplégie-mydriase donna:

O.D. (90°-2d.) + 3d. avec "goutte de l huile" au centre du champ pupillaire.  
O.G. (90°-2d.) + 3.50d.

La skiascopie faite sous myosis (pilocarpine) qui confirma le diagnostic de lenticône, donna:

O.D. - 2d.  
O.G. (180° - 2d.) - 5d.

Acuité visuelle: O.D. 2/10 sans correction.  
O.G. 2/10 sans correction.

L'on obtien: O.D. 6/10 avec (180° - 2d.) - 3d.  
O.G. 3/10 avec (180° - 2d.) - 3d.

L'acuité visuelle s'améliora en instillant myotique (pilocarpine) et en augmentant la correction optique et l'on obtient:

O.D. 7/10 avec (180° - 2d.) - 4d.  
O.G. 4/10 avec (180° - 2d.) - 3d.

Dont, pour résoudre partiellement son probleme l'on prescrit des verres avec 1 dioptrie de moins, tant du verre sphérique comme du verre cylindrique, en indiquant de continuer avec l'emploi de pilocarpine a 2% afin d'éviter l'aberration de la zone périphérique ou circondate du lenticône.

*Evolution.* Un nouvel examen, six mois après ne décéla aucune modification de l'état oculaire. La vision l'one trouva sans aucune variation.

Huit mois après l'on ne constata changement d'importance, sauf legère augmentation de la proéminence du lenticône, spécialement a l'O.G., confirmée par l'augmentation de la réfraction, ayant obtenue une acuité visuelle de 4/10 avec (180° - 2d.) - 12d.

Un an après, le malade se plaint de diminution visuelle; en effet, l'on trouve, toujours sous myosis pilocarpinique, V.O.D. 1/10 sans correction et 4/10 avec (180° - 2d.) - 9d. et V.O.G. 1/10 sans correction et 2/10 avec (180° - 2d.) - 12d.

Ce qui confirme la progres du lenticône.

Huit mois après l'examen précédent le malade revient éprouvant à nouveau une diminution visuelle. L'examen nous montra une legère augmentation de la

ou proeminence du lenticône. Très notoire aspect *chagriné* de la capsule antérieure; 2 petites opacités sous-capsulaires en dessous du centre du cristallin à l'O.D. et petite opacité au noyau foetal de cet oeuille et au noyau embryonnaire de l'O.G. Du reste, l'examen laissa voir état normal de la conjunctive, minimales opacités à la cornée (déjà décrites lors du premier examen). Chambre antérieure, iris, pupille et ses réflexes, tout normal. De même le fond et la motilité extrinseque. L'état visuel était comme ceci:

O.D. 4/10 avec (180° - 2d.) - 11d.

O.G. 2/10 avec (180° - 2d.) - 12d.

Dans le temps écoulé entre l'avant dernier et le dernier temps de l'examen du patient il a souffert de *néphropathie* qui ceda avec un traitement convenable.

La circonstance de la *néphropathie* d'auparavant éveilla notre intérêt, et déjà avec la connaissance de la triade que caractérise le syndrome d'Alport nous décida à faire une nouvelle et très minutieuse investigation laquelle nous apporta plusieurs renseignements très importants, à savoir:

a) Chez le malade: probables états de *néphropathie* avant qu'il vienne à la consultation. Hypoacousie, semble-t-il, avant l'emploi de la streptomycine.

b) Chez sa famille: grande-mère paternelle morte de *néphropathie*, de longue durée compliquée de cardiopathie et de hépatopathie. La mère eu à l'âge de 15 ans *néphropathie* de longue durée et très grave; guérie après beaucoup de temps. et ne souffra plus de troubles de type rénal.

Tenant compte de ces antécédents l'on continua l'investigation et l'on trouva ceci:

a) Chez le malade:

*Analyse d'urines*: réaction acide; sédiment augmenté; chlorures 9.1 gr. ‰; albumine gr. 0,7‰ - Vestiges d'urobiline. Forts indices de sang.

*Examen microscopique*: grande quantité d'hématies; rares cellules de desquamation et leucocytes, quelques cylindres granuleux. A l'examen bactériologique du sédiment, coloration au Gram, quelques germes Gram-négatifs; au Ziehl-Neelsen aucun bacille acidoalcool résistant.

*Comptage d'éléments figurés*:

Hématies: 460.400.000 en 12 heures (normal: 0 à 500.000 en 12 hs.) Leucocytes: 402.700 en 12 heures (normal 1.000.000 en 12 heures). Cellules épithéliales: 322.000 en 12 heures.



Cylindres granuleux: 40.300 en 12 heures.

Leucocyturie par minute: 559 leucocytes.

Protéinurie par minute: 0.7 mgrs. de protéines.

(Pendant la crise néphropathique passée, l'analyse d'urines commandé par le clinicien montra ceci: albumine gr. 1.6‰; sang, abondante; a l'examen microscopique des hémathies nombreux et quelques cylindres granuleux).

*Détermination des séroprotéines.* Protéïnemie totale, normal avec hypoalbuminémie et hyperglobulinémie. Rapport albumine diminué. Fractions globuliniques normales. Alpha 2-globuline en limites normales.

*Hémogramme.* Chiffres normaux apart légère éosinophilie.

Index Katz 3.75

Urée 0.46 gr. ‰.

Glucose 0.89 gr. ‰.

*Examen clinique général,* réalisé par un pédiatre.

Appareils et systèmes: Digestif, rien de particulier. Respiratoire, normal. Circulatoire: coeur, fréquence, rythme, tonus normaux, pas de bruits, de souffles ni *thrill*; pouls 80 r. c. Pression artérielle, mx. 115 et mn. 72 mm. Génital, normal. Hématique et lymphatique, rien de particulier. Endocrine, (système), cliniquement normal. Musculature générale, normal. Système nerveux, rien de spécial. Peau, muqueuses et annexes, aussi normaux.

D'après les antécédents et examens de laboratoire l'on a pu assurer la conclusion diagnostique de *néphropathie*, probable glomérulo-néphrite diffuse, atypique, a poussées, familiale.

*Examen otologique.* Hypoacousie, probablement depuis l'âge de 4 ans, (avant d'être soumis à l'action de streptomycine) et franchement notée à l'âge de 7 ans. Amygdalite a répétition, pour arriver à le faire amygdalectomie, lui ayant donné en tout 18 grammes de strptomycine associé à péniciline en forme discontinue.

Conclusion hypoacousie de perception aux deux cotés, plus accusée pour les tons aigues, en partant de la fréquence de 1.500, sans lésion de la branche vestibulaire; probable surdité congénitale.

b) Chez la famille.

*Père.* E.B.P., d'âge de 41 ans.

Etat oculaire: hémorragies sous-conjonctivales, répétées à quatre occasions diverses. Le reste de l'oeil normal, sauf un léger syndrome vasculaire hypertensif dans le fond.

Etat général: examen clinique négatif. Hémogramme en de chiffres normaux.

Urines normales.

Appareil auditif: hypoacousie neurale à partir de la fréquence de 3.000, que l'otologiste rapporte a parotidite ourlienne de l'enfance.

*Mère.* B.M., d'âge de 37 ans.

Néphropathie à l'âge de 15 ans.

Etat oculaire: aux deux cotés, normaux.

Etat général: examen clinique négatif.

Urines: traces d'albumine, indices de glucose; - traces de *sang*.

A l'examen microscopique: des rares *hemathies*, quelques leucocytes, cristaux d'oxalate de calcium.

Appareil auditif normal.

*Frères:*

1) A.B.M. Age 18 ans. Homme.

Etat oculaire normal aux deux cotés.

Etat général sans aucune particularité. Urines, traces d'*albumine* et de glucose, le resta normal.

Appari eil auditif normal.

2) A.B.M. 17 ans, femme.

Etat oculaire normal de deux cotés.

Etat général, rien de particulier. Urines: vestiges d'albumine et de glucose, le reste normal.

Appareil auditif: *hypoacousie légère*, de 10 decibels dans la fréquence de 4.000.

3) G.B.M. 11 ans, fillette.

Etat oculaire. A l'O.D. petites et tenues opacités kératiques en Descemet, comme formées par des petites bulles d'air, souscentriques, d'un aspect exactement égal à celles trouvés chez notre patient de lenticône et à celles aussi de la soeur cinquième (5.-F.B.M.). Le reste des yeux normal.

## SYNDROME D' ALPORT

Etat général: antécédents de probable néphropathie, examen clinique négatif.

Urines: *albumine* gr. 0,30‰ Vestiges d'urobiline, fortes traces de *sang*; examen microscopique montre nombreux hématies, quelques leucocytes, rares cellules épithéliales. Appareil auditif normal.

4) R.B.M. Fillette, 9 ans.

Etat oculaire, normal des deux cotés.

Etat général, rien de spécial. Urines, vestiges évidentes d'*albumine*.

Vestiges de glucose et d'urobiline. Indices assez marqués de *sang*. Examen microscopique: hématies, cellules épithéliales, sporadiques leucocytes.

Appareil auditif normal.

5) F.B.M. Fillette, 5 ans.

Etat oculaire: aux deux yeux tenues opacités cornéennes en Descemet avec un aspect égal que celles de son frère le patient objet de cet travail et de sa troisième soeur, situées à mi-chemin entre le centre et la périphérie; au surplus, à L'O.G. tenues opacités, allongées verticalement, dans l'endothèle.

Le reste des yeux normal.

Etat général; aucune particularité anormale. Urines avec légères traces d'*albumine* et d'urobiline, et vestiges de *sang*; à l'examen microscopique, de nombreux leucocytes et peu d'*hématies* et cellules épithéliales.

Appareil auditif normal.

## COMMENTAIRE.

Nous croyons nous trouver dans de conditions de pouvoir assurer, avec de raisons suffisantes, que les cas présenté correspond bien à un *évident syndrome* d'Alport. Cependant, afin de laisser ouverte la possibilité de discussion, nous allons comparer, en les résumant, les faits les plus saillants capables d'être motif de controverse.

A) En faveur du syndrome:

- 1). Atteinte oculaire touchant le cristallin, la "vedette" du syndrome-avec son lenticône antérieur franc.
- 2). Néphropathie a caractère éminemment familiale: mère et *tous* les frères avec albuminurie et la plupart avec hématurie.

3). Surdit , aussi avec incidence familiale: 2 me sœur.

B) Contre le syndrome:

- 1). Amygdalite, que l'on pourrait supposer la cause de la n phropathie.
- 2). Impregnation toxique, probable, du nerf acoustique, par streptomycine, que l'on pourrait supposer comme cause de la surdit .

La tendance naturelle   retrouver de nouveaux cas des syndromes peu fr quents justifie l' norme attrait de d nommer le cas pr sent  comme un l gitime syndrome d'Alport, et au surplus que l'analyse des faits co incidents, dans ce cas, ne peuvent de par se nombre et son  loquence  tre purement par hasard. Cependant, le scepticisme scientifique pousse   saisir le cas ou   poser quelques doutes de par les ant cedents que l'obscurcissent peut- tre un peu: surdit  toxique?; —n fropathie post-amydaliennne?

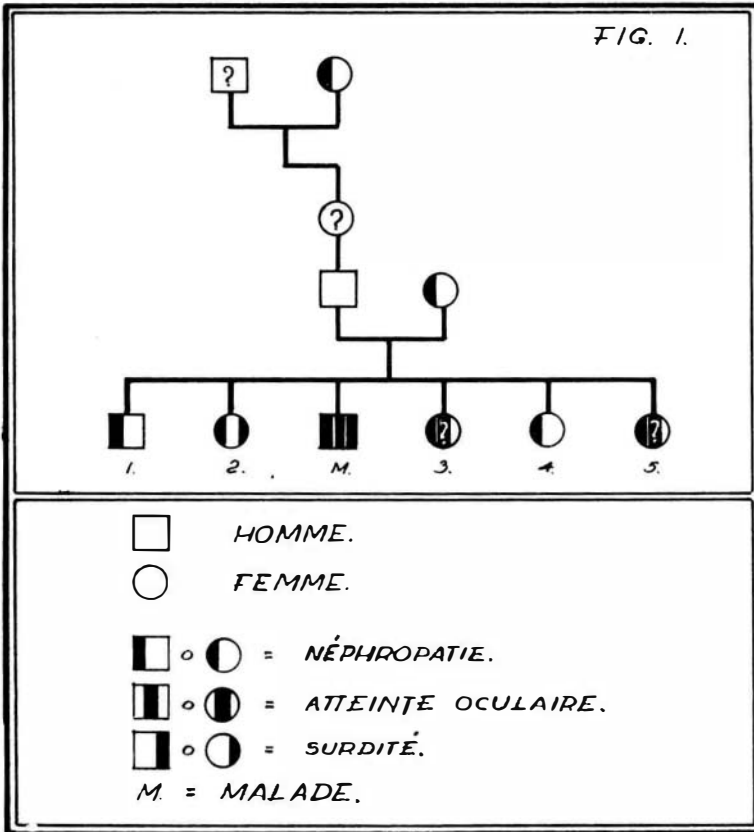

Fig. 1

*RESUME*

L'auteur présente un cas de néphropathie familiale avec surdité et atteinte oculaire (Syndrome d'Alport), lequel peut-être discuté et analysé en raison des quelques particularités qui le caractérisent.

*RESUMEN*

El autor presenta un caso de nefropatía familiar con sordera y afección ocular (Síndrome de Alport) el cual puede ser discutido y analizado en vista de las particularidades especiales que le rodean.

*SUMMARY*

The author presents a case of inherent nephropathy with deafness and ocular affection (d'Alport's Syndrome) which may be perhaps discussed and investigated in view of a few particular characteristics.

*ZUSAMMENFASSUNG*

Der Autor legt einen Fall von familiärer Nephropathie mit Taubheit und angegriffener Sehkraft vor (Syndrom von Alport) über welchen ein Meinungs-austausch vorgenommen werden kann in Anbetracht gewisser Eigenheiten, welche für ihn charakteristisch sind.

*BIBLIOGRAPHIE*

- <sup>1</sup> ALPORT, A. C.: Hereditary familial congenital haemorrhagic nephritis. Brit. M. J. 1: 504 (1927).
- <sup>2</sup> BOUCHET, M. et PAQUELIN: Syndrome familial de néphropathie avec surdité (étude clinique et génétique). Ann. Oto-laryng. 73: 895 (1956).
- <sup>3</sup> FRANCOIS, J.: Les cataractes congénitales. Rapport Société Française d'Ophthalmologie Masson et Cie. édit. Paris (1959).
- <sup>4</sup> GOLDBLOOM, R. B.; FRASER F. C.; WAUGH, D.; ARONOVITCH, M. et WIGLESWORTH, F. M.: Hereditary renal disease associated with nerve deafness and ocular lesions. Pediatrics. 20: 241 (1957).
- <sup>5</sup> GREGG, J. B. et BECKER, S. F.: Progressive deafness, chronic nephritis and crystalline lesions. Arch. Ophth. 69: 293 (1963).

- 6 JULIEN MARIE, ROYER, P.; RABIB, R.; MATHIEU, H. et REVEILLAND, R. J.: Le néphropathie hématurique héréditaire avec surdité Semaine Hôp. Paris, Ann. Pédiat. 36: 84 (1960).
- 7 JUNOD J. P.: Les néphropathies héréditaires avec atteinte oculaire et auditive Actualités Néphrologiques de l'Hôp. Necher. 29: 95. Edit. Flammarion (1963).
- 8 METTIER, S. R.: Ocular defects associated with familial renal disease and deafness of hereditary interstitial pyelonephritis. Arch. Int. Med. 88: 191 (1951).
- 9 PERKOFF, G. T.; STEPHENS, P. E.; DOLLOWITH, D. A. et TYLER, F. H.: A clinical study Arch. Ophth. 65: 386 (1965).
- 10 PERRIN, D.: Le lenticonet-il une atteinte oculaire nouvelle du syndrome néphropathie familiale-surdité-malformations oculaires?. Mémoire Institut National d'Hygiène. Paris (1960).
- 11 PERRIN, D.: Contribution a l'étude du syndrome: néphropath'e familiale surdité-malformations oculaires. Thèse. Paris (1962).
- 12 PERRIN, D.: Le syndrome d'Alport (néphropathies héréditaires avec surdité et atteinte oculaire). Ann. Oculist. 197: 329 (1964).
- 13 REYERSBACH, G. C. et BUTTLER, A. M.: Case records of the Massachusetts General Hospital. New England J. Med. 257: 1231 (1957).
- 14 SOHAR, E.: A. heredo-familial syndrome characterized by renal disease, inner ear deafness and ocular changes. Harefuah. 25: 161 (1954).

## THE MOSES EFFECT DURING IN VIVO IMPRESSION TONOMETRY ON THE RABBIT EYE

BY

E. WEIGELIN, M. D., W. ZIESMER, M. D.

Bonn - Germany

### *Definition of the problem*

Specification N<sup>o</sup> IV of the American Committee for the standardization of impression tonometers provides definite norms for most parameters of tonometers. The size of the foot-plate hole was not considered in this specification. Experiments performed by MOSES and HAHN in 1958 and by MOSES in 1959 on enucleated human and rabbit eyes, demonstrated that the magnitude of the scale reading of an impression tonometer is also affected by the size of the foot-plate hole, especially with high intraocular pressures. These authors were able to demonstrate on the basis of photographic pictures and by using a translucent tonometer foot, that the plunger of the apparatus does not sink into a flattened-out cornea as was assumed until then, but into a cornea that prolapses into the hole. As a result of this the scale reading is decreased, especially in the higher pressure ranges, i.e., the scale reading is too high. Due to these findings specification N<sup>o</sup> V of the American committee then fixed the upper limit of the size of the foot-plate hole at 3.7 mm. This failed to take into consideration, that according to the most recent tests of MOSES, the scale readings of tonometers with a foot-plate hole of 3.3 mm differ quite definitely from such with foot-plate holes of 3.7 mm and more.

The pending legal calibration requirements in the Federal Republic of Germany for all equipment which is used in the field of medicine for pressure measurements, made it essential to re-examine this situation once more. Beside experiments on enucleated human eyes (FRIEDRICH, 1966) we performed in vivo tests on rabbit eyes which we wish to report in this paper.

*Methods*

The Federal Physical-Technical Institute in Berlin made 6 tonometers available to us and these tonometers were almost identical in all parameters and within the tolerance limits, with the exception of the diameter of the foot-plate hole. This was 3.15 mm, 3.23 mm, 3.37 mm, 3.43 mm, 3.50 mm and 3.55 mm. All diameters thus were within the limits allowed by specification N<sup>o</sup> V.

13 anesthetized rabbits served as experimental animals. Their weight ranged from 2.5 - 3.0 kg.

The apparatus used for pressure adjustment and pressure measurement manufactured by the Federal Physical-Technical Institute in Berlin, is reproduced in illustration N<sup>o</sup> 1. A N<sup>o</sup> 14 needle introduced into the anterior chamber at the

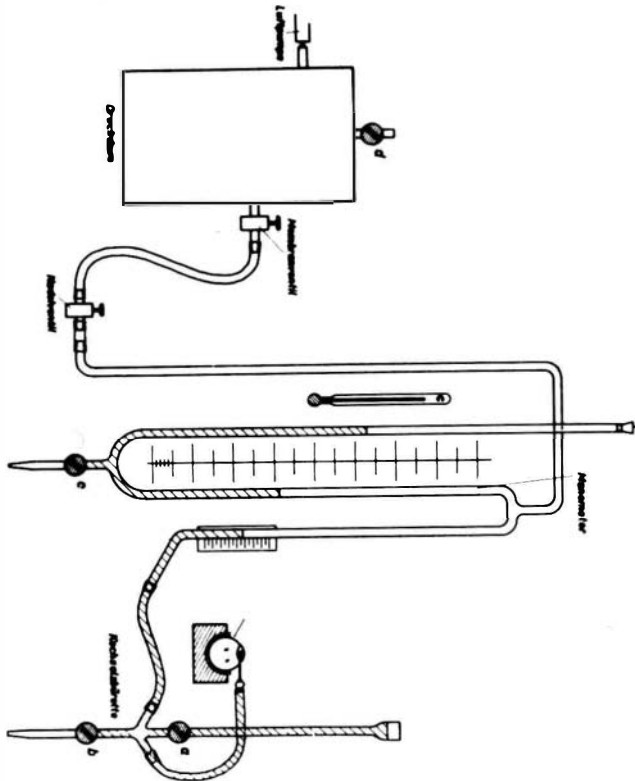

Fig. 1: Schematic representation of the apparatus, consisting of a pressure can, a manometer and a saline burette.

limbus formed the connection between the eye and the measuring apparatus. At a fixed pressure each of the 6 tonometers was applied, in different sequence,



to the eye bulb and the deflection of the pointer was read from the scale. These measurements were first performed with increasing and then with decreasing manometer adjustments. Thus we obtained 140-150 pressure reading (Pt) and pointer deflection readings (R) from each of the 6 tonometers.

*Results:*

The equation of Friedenwald  $W/P_t = a + b \cdot R$  served as the basis for the evaluation of the results.  $W/P_t$  is obtained from the tonometer weight and the manometer reading, R is obtained from the corresponding pointer deflection, a and b can be determined by using regression calculations. A regression calculation was performed for each of the 6 tonometers. Illustration N<sup>o</sup> 2 shows the straight line regression for tonometer N<sup>o</sup> 2 (foot-plate hole diameter 3.23 mm) with the point distribution. The regression coefficient b became smaller as the size of foot-plate hole increased while the point of bisection with the ordinate of the system (a) became larger. The magnitude of b did not differ significantly in tonometers with foot-plate holes ranging from 3.15 to 3.37 mm or between the two tonometers with foot-plate hole diameters of 3.43 mm and 3.50 mm. Otherwise, definitely significant differences were present and these were entirely in the stated sense: the larger the foot-plate hole, the flatter was the angle of

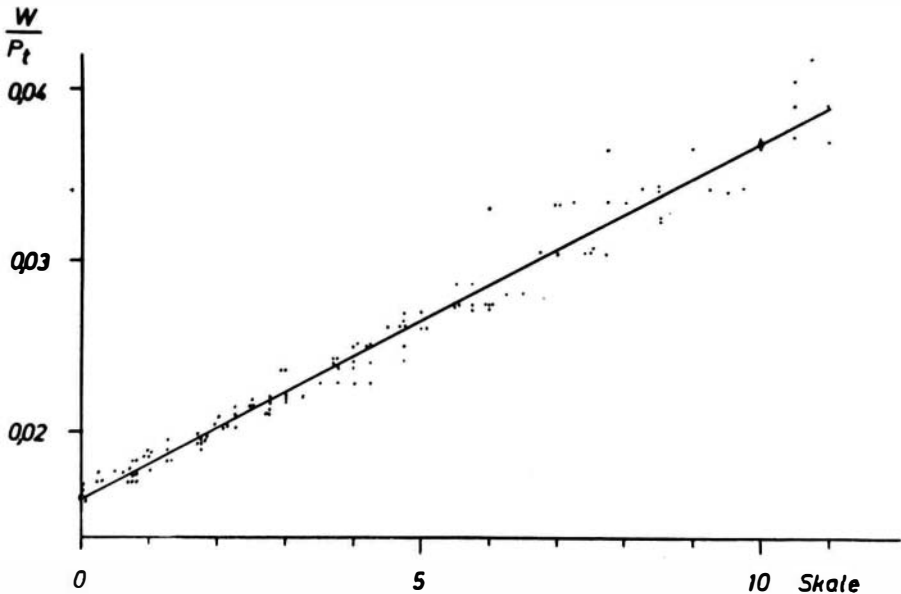

Fig. 2: Straight line regression of tonometer N<sup>o</sup> II.

elevation of the regression straight line and the higher was the point of bisection with the ordinate (illustration N<sup>o</sup> 3).

After calculation of the equation constants a and b it is possible to assign a pressure reading  $P_t$  to each scale reading R. The result for 3 tonometers is reproduced in illustration N<sup>o</sup> 4. The correlation curves between  $P_t$  and pointer deflection R, even with our small differences in the diameters of the foot-plate holes, coincide with the curve obtained by MOSES in tests with larger differences. Even at pointer deflection 5 an already quite definite difference is present, which becomes increasingly larger towards 0. With a pressure of 250 mm

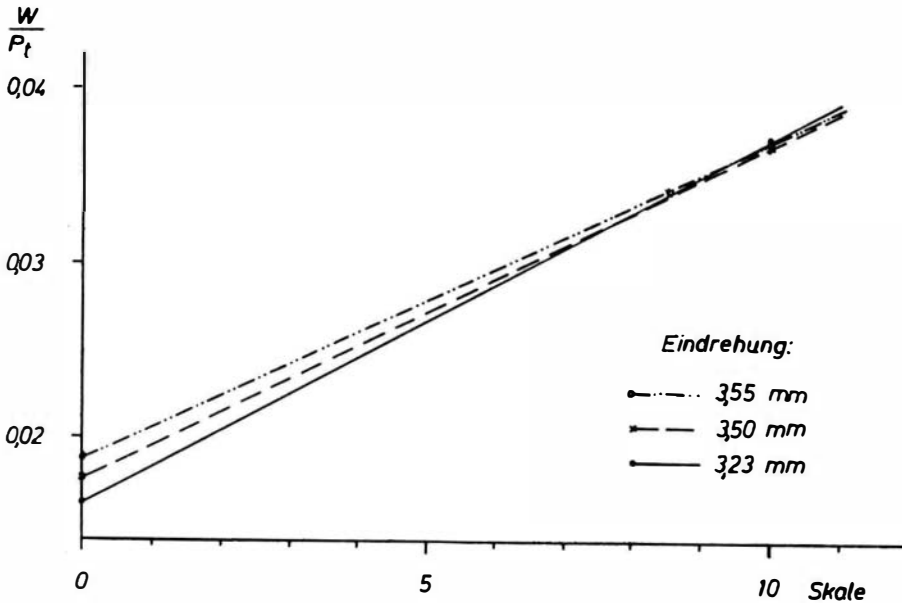

Fig. 3: Straight line regression of tonometers

fluid column (density of the manometer fluid = 2.17) the tonometer with the largest foot-plate hole diameter showed a scale reading of approximately 2, that with the smallest foot-plate hole of approximately 3. Due to the MOSES effect one may assume, that the pointer deflection 2 is the result of prolapse of the cornea into the foot-plate hole and thus is incorrect. The intra-ocular pressure obtained with such a tonometer is thus read too high from the calibration table. However, and this has been already pointed out by MOSES, this effect is larger in rabbits than in humans on account of the thinner rabbit sclera.

As these tests and the tests performed by FRIEDRICH on human human eyes have demonstrated, that the size of the foot-plate hole diameter affects the reading of the impression tonometer, it appears that more exact standardization of this parameter is essential. As production difficulties do not result from this, German legal calibration will require a foot-plate hole diameter of  $3.3 \pm 0.5$  mm.

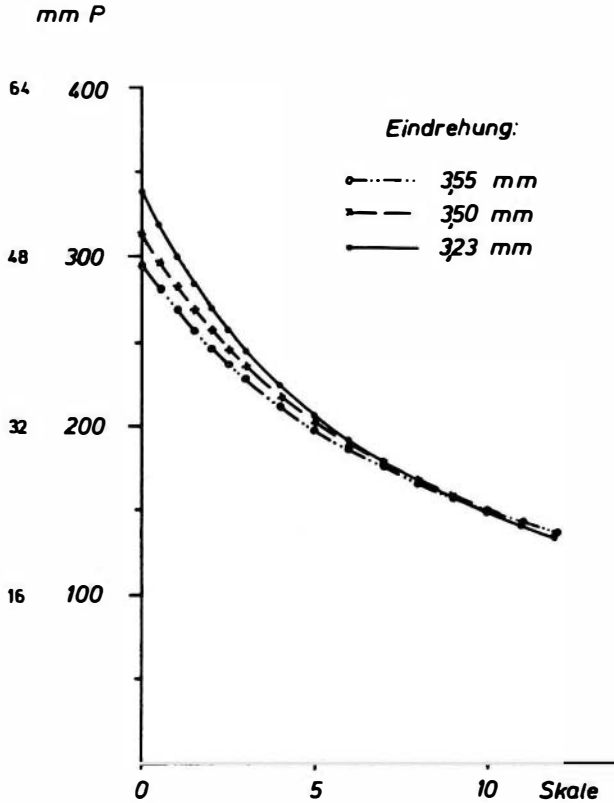

Fig. 4: Correlation curve between intraocular pressure (Pt) and pointer deflection (R) of tonometers II, V and VI.

*Summary:*

On the basis of in vivo tests on rabbit eyes the author reports about the effect of the diameter of the foot-plate hole of Schiötz-tonometers (Moses effect) on the measurement result. Even small differences of the diameter alter the measurement results in the manner stated by MOSES.

## NECROLOGICA

Mr. Peter Vere Rycroft, M.A., M.D., F.R.C.S., D.O.



Peter Rycroft died tragically on January 6 th., as a result of a motor accident. He was thirty nine years of age. His early medical career as a student was at Trinity College, Cambridge University and his clinical studies were undertaken at St. Bartholomew's Hospital, London.

After a house surgeon's appointment at St. Bartholomew's and service in the Royal Army Medical Corps he decided to specialize in ophthalmology. He was House Surgeon and later senior Resident Officer at Moorfields Eye Hospital.

He obtained his Diploma in Ophthalmology in 1959 and became a fellow of the Royal College of Surgeons of England in 1963.

After his residency at Moorfields he was appointed ophthalmic registrar at Guy's Hospital and clinical assistant at the Queen Victoria Hospital, East Grinstead.

He was always interested in surgical ophthalmology and especially in the surgery of the cornea. He was a meticulous and talented surgeon but besides his practice of clinical surgery, he spent much time in active research into the biological aspects of corneal transplantation. He investigated extensively the changes occurring in stored donor corneal material which might affect the transparency of corneal grafts. Much of this research was carried out as research ophthalmologist to the Pocklington Eye Research Unit at the Royal College of Surgeons, and here he was able to enjoy working in close collaboration with his father the late Sir Benjamin Rycroft. His corneal research work formed the basis of his thesis for the degree of Doctor of Medicine at Cambridge University.

Last July, the Second International Corneo Plastic Conference was held at the Royal College of Surgeons, and Ophthalmologists and Plastic surgeons from thirty eight different countries took part. Owing to the sudden death of his father earlier in the year. Peter was left with the task of organizing the final arrangements. He worked with unbounded energy and enthusiasm to ensure the success of the meeting. This was no easy task since the conference consisted of five fully packed days of scientific and social activity. I know that everyone who had the pleasure of attending the meeting will agree that the outstanding success of the occasion was due above all to the organizing ability and hard work of Peter Rycroft encouraged and assisted at all times by his devoted wife Margaret.

He had travelled widely and had contributed to many ophthalmic meetings; his many friends from all parts of the world are, I know, saddened by his sudden death and feel it as a great personal loss.

To his wife, his three sons and his mother Lady Rycroft, we offer our sincerest sympathy.

*Derek Ainslie*

## NOTÍCIAS

### XVº Congresso Brasileiro de Oftalmologia

Será realizado, em Pôrto Alegre, Rio Grande do Sul, de 27 de abril a 2 de maio de 1969, o XVº CONGRESSO BRASILEIRO DE OFTALMOLOGIA, que deverá reunir um número realmente extraordinário de especialistas, não só do Brasil, como também do Exterior.

Já estão bastante adiantados os trabalhos da Comissão Executiva do Congresso, assim constituída — Presidente de Honra, Prof. Ivo Corrêa Meyer; Presidente, Prof. Luis Assumpção Osório; Secretário, Prof. Mário Araujo Azambuja; Tesoureiro, Dr. Paulo Fernando Esteves.

Assim, já foi elaborado o programa científico, que constará de dois Temas Oficiais:

1º *Fotocoagulação e Laser*, tendo como Coordenador o Dr. Nelson Moura Brasil do Amaral (Rio de Janeiro) e, como Relatores, os Professores Sergio Cunha (São Paulo), Raul Rodriguez Barrios (Uruguay), Luiz Eurico Ferreira (Rio de Janeiro), Joaquin Marinho de Queiroz (Belo Horizonte) e os Drs. Laborne Tavares (Belo Horizonte) e Joviano Rezende (Rio de Janeiro).

2º *Glaucoma Congênito*, tendo como Relatores os Professores Celso Antônio de Carvalho (São Paulo) e Nassim Calixto (Belo Horizonte).

Haverá, ainda, mais dois Simpósios: — um, sobre *Olho e Rim*, que terá como Coordenador o Prof. Silvio de Abreu Fialho (Rio de Janeiro) e Relatores os Professores Antônio Borrás (Uruguay), Paulo Filho (Rio de Janeiro), Renato Toledo (São Paulo) e Paulo Braga Magalhães (São Paulo); e outro Simposio, sobre *Olho Miope*, terá como Coordenador o Prof. Clovis Paiva (Recife) e Relatores os Professores Rubens Belfort Mattos (São Paulo), Humberto Castro Lima (Salvador), Francisco de Paula Soares Filho (Curitiba), Egons Armando Krueger (Curitiba), Rivadavia M. Correa Meyer (Pôrto Alegre), Joaquim Ma-

## NOTÍCIAS

### XVº Congresso Brasileiro de Oftalmologia

Será realizado, em Pôrto Alegre, Rio Grande do Sul, de 27 de abril a 2 de maio de 1969, o XVº CONGRESSO BRASILEIRO DE OFTALMOLOGIA, que deverá reunir um número realmente extraordinário de especialistas, não só do Brasil, como também do Exterior.

Já estão bastante adiantados os trabalhos da Comissão Executiva do Congresso, assim constituída — Presidente de Honra, Prof. Ivo Corrêa Meyer; Presidente, Prof. Luis Assumpção Osório; Secretário, Prof. Mário Araujo Azambuja; Tesoureiro, Dr. Paulo Fernando Esteves.

Assim, já foi elaborado o programa científico, que constará de dois Temas Oficiais:

1º *Fotocoagulação e Laser*, tendo como Coordenador o Dr. Nelson Moura Brasil do Amaral (Rio de Janeiro) e, como Relatores, os Professores Sergio Cunha (São Paulo), Raul Rodriguez Barrios (Uruguay), Luiz Eurico Ferreira (Rio de Janeiro), Joaquin Marinho de Queiroz (Belo Horizonte) e os Drs. Laborne Tavares (Belo Horizonte) e Joviano Rezende (Rio de Janeiro).

2º *Glaucoma Congênito*, tendo como Relatores os Professôres Celso Antônio de Carvalho (São Paulo) e Nassim Calixto (Belo Horizonte).

Haverá, ainda, mais dois Simpósios: — um, sôbre *Olho e Rim*, que terá como Coordenador o Prof. Silvio de Abreu Fialho (Rio de Janeiro) e Relatores os Professôres Antônio Borrás (Uruguay), Paulo Filho (Rio de Janeiro), Renato Toledo (São Paulo) e Paulo Braga Magalhães (São Paulo); e outro Simposio, sôbre *Olho Miope*, terá como Coordenador o Prof. Clovis Paiva (Recife) e Relatores os Professôres Rubens Belfort Mattos (São Paulo), Humberto Castro Lima (Salvador), Francisco de Paula Soares Filho (Curitiba), Egons Armando Krueger (Curitiba), Rivadavia M. Correa Meyer (Pôrto Alegre), Joaquim Ma-

rinho de Queiroz (Belo Horizonte), Silvio Paes Barreto (Recife), Dr. Emir Francisco Soares (Belo Horizonte) e Prof. Geraldo Queiroga (Belo Horizonte).

Os Professôres Jorge Malbran (Argentina), Hilton Rocha (Belo Horizonte) e Almiro Azeredo (Ribeirão Prêto) pronunciarão Conferencias.

Foram convidados diversos Professôres estrangeiros e nacionais para ministrar  *cursos de pequena duraço*, paralelos com as atividades oficiais do Congresso. É pensamento da Comissão Exejeutiva dar ênfase tôda especial a êstes Cursos.

Após a realização das Sessões do Congresso, terá lugar a *Reunião do Centro Brasileiro de Estrabismo*, presidido pelo Dr. José Belmiro de Castro Moreira (São Paulo), tendo como convidado de honra o Prof. Marshall M. Parks (U.S.A.).

Os colegas interessados em apresentar Temas Livres ou Filmes, deverão enviar, com urgência, os seus títulos, para organização do programa, a Secretaria do Congresso, no Hospital das Clínicas, sala 17 - *Pôrto Alegre*.

*Enderêço: Rua Jardim Cristófel, 44 apto. 80 (Bairro Independencia)*

Porto Alegre - Rio grande do Sul.  
Brasil.



# Sociedad Americana de Oftalmología y Optometría

## ACTIVIDADES CIENTIFICAS PARA 1969 1969 SCIENTIFIC ACTIVITIES

### JANUARY 16

- |   |  |                                       |              |
|---|--|---------------------------------------|--------------|
| 8 | A. M. Surgical Session.<br>Sesión Quirúrgica.  |                                       |              |
| 8 | P. M. Conference: Cellular survival in corneal freezing.<br>Conferencia: Supervivencia celular en congelaciones corneales. | <b>Dr. Angel Hernández,</b><br>(COL.) | <b>M. D.</b> |

### FEBRUARY 6

- |   |   |                                      |              |
|---|---|--------------------------------------|--------------|
| 8 | A. M. Surgical Session.<br>Sesión Quirúrgica.   |                                      |              |
| 8 | P. M. Conference: Concepts updating functional exploration in refractive Keratoplasty . . . . .<br>Conferencia: Actualización de conceptos en exploración funcional en queratoplastias refractivas. | <b>Dr. Hernando Henáo,</b><br>(COL.) | <b>O. D.</b> |
|   | Conference: Ocular Prosthesis. Confection and technique . . . . .<br>Conferencia: Prótesis oculares. Técnica de Confección.   | <b>D. Delfin Borrero,</b><br>(COL.)  | <b>M. D.</b> |

### MARCH 6

- |            |   |  |              |
|------------|---|--|--------------|
| 8          | A. M. Surgical Session.<br>Sesión Quirúrgica.   |  |              |
| 7 :30 P.M. | Conference: Contact Lenses . . . . .<br>Conferencia: Lentes de Contacto.  | <b>Dr. Oscar Córdova,</b><br>(PERU)                  | <b>M. D.</b> |
|            | Conference: Techniques of Cataract Surgery . . . . .<br>Conferencia: Técnicas en cirugía de cataratas.  | <b>Dr. Ira A. Abrahamson Jr. M. D.</b><br>(U. S. A.) | <b>M. D.</b> |
|            | Conference: Cryoextraction of the lens. Technique and results . . . . .<br>Conferencia: Crioeextracción del cristalino. Técnica y resultados. | <b>Dr. José I. Barraquer,</b><br>(COL.)              | <b>M. D.</b> |

### APRIL

- |   |  |  |              |
|---|--|--|--------------|
| 8 | A. M. Surgical Session.<br>Sesión Quirúrgica.  |  |              |
| 8 | P. M. Conference: Clinical measurement of stereopsis ..<br>Conferencia: La medida clínica de la estereopsis. | <b>Dr. Henry Hofstetter,</b><br>(U. S. A.) | <b>O. D.</b> |

### MAY 8

- |   |   |   |                              |
|---|---|---|------------------------------|
| 8 | A. M. Surgical Session.<br>Sesión Quirúrgica.                                   |   |                              |
| 9 | A. M. Conference: Orthokeratology . . . . .<br>Simposio sobre Ortoqueratología. | <b>Dr. Charles H. May</b><br>(U. S. A.)<br><b>Dr. Stuart C. Grant</b><br>(U. S. A.) | <b>O. D.</b><br><b>O. D.</b> |

PRIMUM FORUM OPHTHALMOLOGICUM.  
LUNES 16 A 20 DE MARZO DE 1970.

- |    |  |  |              |
|----|--|--|--------------|
| 10 | A. M. Conference: Contact lenses and ophthalmic anomalies .....<br>Conferencia: Lentes de contacto y anomalías oftálmicas.   | <b>Dr. John Kennedy,</b><br>(U. S. A.) | <b>O. D.</b> |
|    | Conference: The effect of pupil size and shape on aphakics wearing contact lenses .....<br>Conferencia: Efecto de tamaño y forma de la pupila en afaquias cuando se usan lentes de contacto. | <b>Dr. R. Koetting,</b><br>(U. S. A.)  | <b>O. D.</b> |
|    | Conference: Contact lenses care for corrective orthokeratology .....<br>Conferencia: Cuidado de los lentes de contacto para ortoqueratología correctiva.                                     | <b>Dr. Sanford Ziff,</b><br>(U. S. A.) | <b>O. D.</b> |
| 8  | P. M. Conference: Toxicology of local anesthetic agents.<br>Conferencia: Toxicidad de los agentes anestésicos locales.   | <b>Dr. Juan Marín,</b><br>(VENEZ.)     | <b>M. D.</b> |
|    | Conference: Massive vitreous retraction .....<br>Conferencia: Retracción masiva del vítreo.  | <b>Dr. Karl Hruby</b><br>(AUSTRIA)     | <b>M. D.</b> |

**JUNE 5**

- |   |   |   |              |
|---|---|---|--------------|
| 8 | A. M. Surgical Session.<br>Sesión Quirúrgica.   |   |              |
| 8 | P. M. Conference: Optical elements .....<br>Conferencia: Elementos ópticos.   | <b>Dr. Hartmut Weber,</b><br>(COL.)         | <b>O. D.</b> |
|   | Conference: Revascularization of the anterior and posterior segment of the ocular globe .....<br>Conferencia: Revascularización del segmento anterior y posterior del globo ocular. | <b>Dr. Jorge Vasco P.,</b><br>(COL.)        | <b>M. D.</b> |
|   | Conference: To be announced.....<br>Conferencia: Se anunciará.  | <b>Dr. William Dellandte,</b><br>(U. S. A.) | <b>O. D.</b> |

**JULY 3**

- |   |  |   |              |
|---|--|---|--------------|
| 8 | A. M. Surgical Session.<br>Sesión Quirúrgica.                                      |   |              |
| 8 | P. M. Conference: Ocular toxoplasmosis. ....<br>Conferencia: Toxoplasmosis ocular. | <b>Dr. Francisco Rodríguez V.,</b><br>(COL.)      | <b>M. D.</b> |
|   | Conference: Pterygium Surgery .....<br>Conferencia: Cirugía del Pterigion. ....    | <b>Dr. Fernando Gómez da Silveira</b><br>(BRASIL) | <b>M. D.</b> |

**AUGUST 14**

- |   |   |  |  |
|---|---|--|--|
| 8 | A. M. Surgical Session.<br>Sesión Quirúrgica.   |  |  |
| 8 | P. M. Conference: Treatment of amblyopia .....<br>Conferencia: Tratamiento de la ambliopía. | <b>Dr. Claudio H. Savastano, M. D.</b><br>(BRASIL) |  |

**SEPTEMBER 4**

- |   |   |  |  |
|---|---|--|--|
| 8 | A. M. Surgical Session.<br>Sesión Quirúrgica. |  |  |
|---|---|--|--|

**PRIMUM FORUM OPHTHALMOLOGICUM.  
LUNES 16 A 20 DE MARZO DE 1970.**

- 8 P. M. Conference: Hardlook on Ophthalmic anesthetics. **Dr. José María Silva, M. D.**  
 Conferencia: Actualización en anestesia oftálmica. (COL.)
- Conference: Rest in Retin Operation. **Dr. Enrique Ariza M. D.**  
 Conferencia: Reposo en desprendimiento de retina. (COL.)

**OCTOBER 2**

- 8 A. M. Surgical Session.  
 Sesión Quirúrgica.
- 8 P. M. Conference: Surgery of the congenital youth cataract . . . . . **Dr. Francisco Barraquer, M. D.**  
 Conferencia: Cirugía de catarata congénita juvenil. (COL.)
- Conference: Dynamic monocular retinoscopy . . . **Dr. Gabriel Merchán, O. D.**  
 Conferencia: Retinoscopia dinámica monocular. (COL.)

**NOVEMBER 6**

- 8 A. M. Surgical Session.  
 Sesión Quirúrgica.
- 8 P. M. Conference: Surgical treatment of Keraoconus... **Dr. José I. Barraquer, M. D.**  
 Conferencia: Tratamiento quirúrgico del queratocono. (COL.)
- Conference: To be announced . . . . . **Dr. Irving Filderman, O. D.**  
 Conferencia: Se anunciará. (U. S. A.)

**DECEMBER 4**

- 8 A. M. Surgical Session.  
 Sesión Quirúrgica.
- 8 P. M. Conference: Orbital Phlebography . . . . . **Dr. Gustavo Scioville, M. D.**  
 Conferencia: Flebografía orbitaria . . . . . (COL.)
- Conference: Leucocoria. Differential diagnosis .. **Dr. Fernando Ríos R. M. D.**  
 Conferencia: Leucocoria. Diagnóstico diferencial. (COL.)

**SOCIEDAD ARGENTINA DE OFTALMOLOGIA**  
**ARCHIVOS DE**  
**OFTALMOLOGIA DE BUENOS AIRES**

**Fundada por el Prof.**

**RAUL ARGANAÑAZ**

---

La publicación —mensual— incluye artículos originales, aprobados en las Sesiones Ordinarias de la S. A. O. Revisión bibliográfica (sumarios) y Crítica Bibliográfica. Además publica Conferencias por invitación y resúmenes de Mesas Redondas.

---

**Director**

**DR. EDGARDO MANZITTI**

**Secretario de Redacción**

**DR. ALBERTO CIANCIA**

---

Las órdenes de suscripción deben ser enviadas al Secretario General:

**Dr. Humberto A. Pérez — Santa Fe 1171, Buenos Aires — Argentina**

**Suscripción anual US \$ 12.00**

# Oftalmómetro de Jena

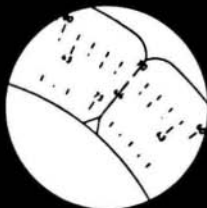
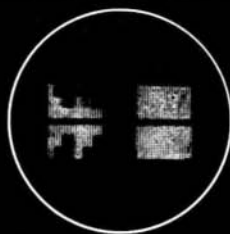

para medir los radios de curvatura de la superficie corneal anterior, el poder de refracción de la córnea, es decir el astigmatismo corneal, la posición de los dos meridianos principales de una córnea astigmática, el poder de refracción de la córnea en cada uno de los dos meridianos principales.

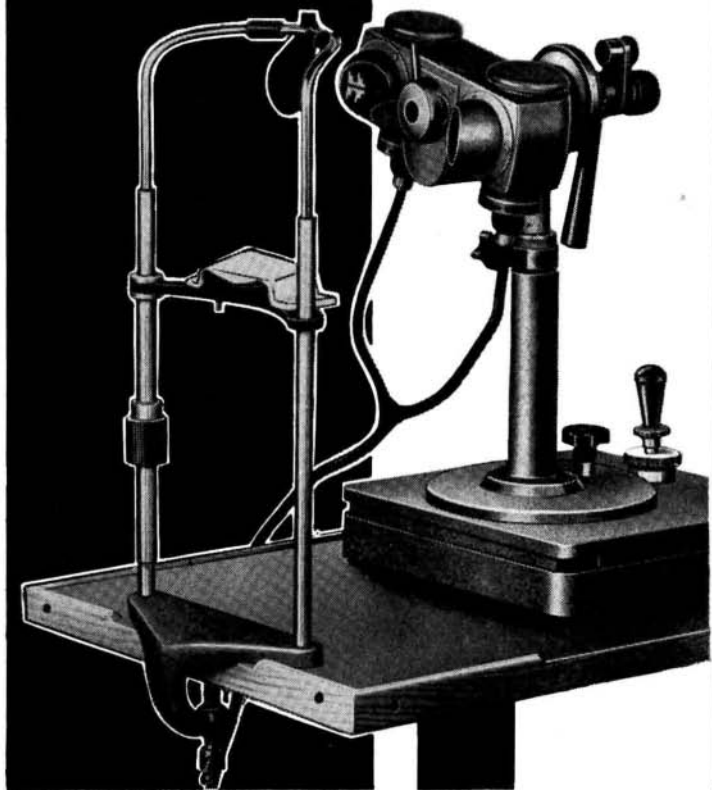

**VEB Carl Zeiss JENA**

**de Jena**

**Precisión y calidad de  
renombre mundial.**

Representantes exclusivos para Colombia: COMPAÑIA COMERCIAL CURAÇAO DE COLOMBIA S. A.  
Oficinas en: Bogotá — Medellín — Cali — Barranquilla

CONSEJO SUPERIOR DE INVESTIGACIONES CIENTIFICAS

ARCHIVOS  
DE LA  
SOCIEDAD OFTALMOLOGICA  
HISPANO - AMERICANA



Director:

B. CARRERAS DURAN., M. D.

Secretario:

JOSE MARIA AGUILAR BARTOLOME., M. D.

Dirección: Calle de Fernando El Católico. 14. Madrid 15

ESPAÑA

**SUSCRIPCION ANUAL: 600 Ptas.**

## **AL SERVICIO DE LOS ESPECIALISTAS EN LENTES DE CONTACTO**

Lentes de Contacto Wesley and Jessen (Sphercon, Cycon, Torcon, Bicon, Sphertan, Sphertints, Pupililentes "W/J"), productos de la

**PLASTIC CONTACT LENS CO., para**

**Miopía - Astigmatismo - Afa quia (Monocular y Binocular) Medio de Diagnóstico - Queratocono - Córneas irregulares y cicatrizadas. Visión sub-normal - Indicaciones Cosméticas.**

Nuestro Departamento de Relaciones Cientificas se encuentra al servicio de los especialistas en Lentes de Contacto, a fin de proporcionar cualquier información.

**REPRESENTANTES EXCLUSIVOS PARA COLOMBIA,**

**PLASTIC CONTACT LENS DE COLOMBIA LTD.**

**Apartado Aéreo N° 20052 - Teléfono 482363**

**Bogotá, D. E., 2, Colombia, S. A.**

**Archivos de la Sociedad Americana de oftalmología y optometría.**

**PARA ANUNCIOS COMERCIALES DIRIGIRSE A**

**CASA HELLER LTDA.**

**APARTADO AEREO 4966 - BOGOTA - COLOMBIA**

Applications and correspondence concerning advertisements please  
address to:

**CASA HELLER LTDA.**

**APARTADO AEREO 4966 - BOGOTA - COLOMBIA**

**CANJE:**

Se solicita canje con las publicaciones congéneres.

On accepte des échanges avec les publications congéneres.

Exchange with similar publications is desired.

Wir bitten um Austausch mit aehnlichen Fachzeitschriften

Aceitan-se permutas con publicações congéneres.

Si desidera il cambio colle pubblicazioni congeneri.

**En las Afecciones Oftálmicas u Oticas**

# Terra- cortril

TERRAMICINA hidro cortisona



**TERRA-CORTRIL**

**Suspensión Oftálmica-Otica**

**Ungüento Otico-Oftálmico, con Polimixina B**





## Productos »Schering A.G.« para Oftalmología

<b>ACTH »Schering A.G.« ACTH-DEPOT »Schering A.G.«</b>	(Hormona adrenocorticotropa) ampollas de 2,5 y 10 U. I. frascos de 5 c.c. con 100 y 200 U. I.
<b>Albucid oftálmico Colirio</b>	(p-aminobenzenosulfonacetilamida sódico) solución al 20%; frascos-pipeta de 10 c.c.
<b>Allerpén</b>	(Allercur-Penicilina) frascos con 400.000 y 800.000 U. I.
<b>Kinadena</b>	(Hialuronidasa) ampollas de 350 U. I.
<b>Delta-Scherosona</b>	(Prednisona) 10 y 30 tabletas de 5 mg. c/u.
<b>Scherisolona</b>	(Prednisolona) 10 y 30 tabletas de 5 mg. c/u.
<b>Scherosona oftálmica</b>	(Cortisona con Cloranfenicol) tubos con 2 g. de solución oleosa
<b>Scherosona F oftálmica</b>	(Hidrocortisona con Cloranfenicol) tubos con 2 g. de solución oleosa

**Schering A.G. Berlin  
Alemania**

Representantes: Química Schering Colombiana Ltda., Bogotá  
Calle 18A No. 33-15 · Tel.: 478415/18  
Aportado aéreo 3559 · Aportado Nacional 147

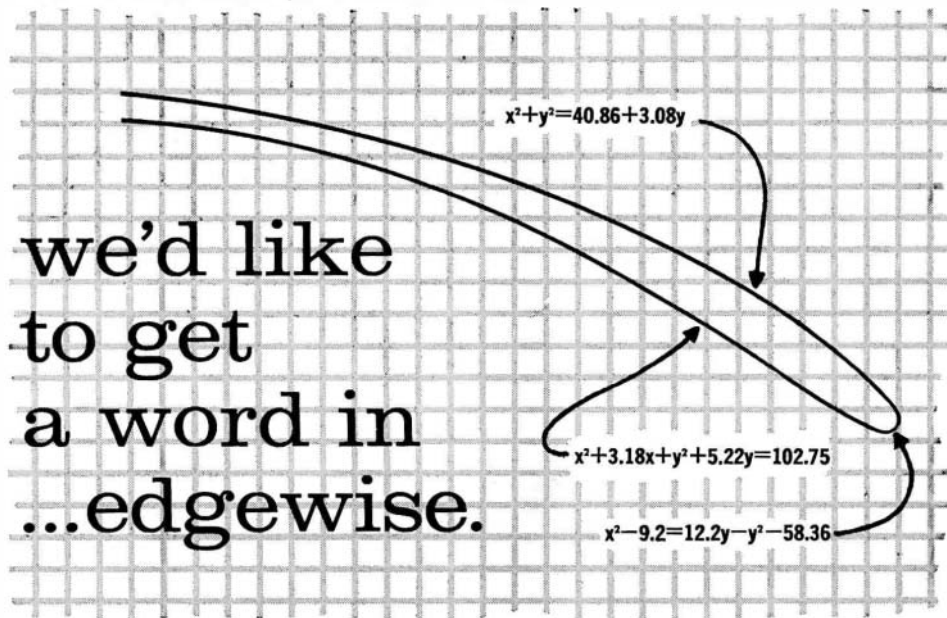

we'd like  
to get  
a word in  
...edgewise.

**CONSISTENT**

is the word that describes the edge of a PARABOLAR fully-finished CONTACT LENS.

**CONSISTENT**

because every PARABOLAR edge is manufactured on specialized, automated equipment, exclusively designed and patented, for precise duplication.

**CONSISTENT**

because—to us—the finishing of a lens is its most important aspect. PARABOLAR CONTACT LENSES, since 1957, have been sold *only* fully-finished, and *only* directly from our laboratory at West Hempstead, N.Y., through an extensive network of professionally trained distributors.

**CONSISTENT**

fitters go from start-to-finish, usually without the time consuming task of re-edging and re-finishing.

— accept no substitute for —

**parabolar<sup>®</sup> parabolette<sup>®</sup>**  
ultra-thin

*the quality, fully-finished contact lenses made only by*

**DANKER & WOHLK, Inc.**

**314 HEMPSTEAD AVENUE • WEST HEMPSTEAD, N.Y.**



# Ultralan

Schering AG Berlin

Pruebe primero ultralan  
el non plus ultra de las  
pomadas corticoides.  
La única con mecanismo  
de acción en dos fases.  
Tubos de 10 y 30 g



# ITALMEX

**“PRODUCTOS CIENTIFICOS”**



**MARTINEZ**  
**NEW DISPOSABLE CORNEAL TREPHINE**

An extremely sharp corneal trephine having the following outstanding features.

Blade penetrates to 1.5mm at which point a stop prevents further penetration.

All stainless steel. Four sizes: 6, 7, 8 and 9mm.

No. E-3174 Each \$6.00

**STORZ INSTRUMENT COMPANY, 4570 Audubon Ave., St. Louis, Mo. 63110**  
New York Showroom: 629 Park Avenue

**INSTITUTO BARRAQUER**

**de  
AMERICA**

**SOCIEDAD AMERICANA**

**de  
OFTALMOLOGIA Y OPTOMETRIA**

Announces its "PRIMUM FORUM OPHTHALMOLOGICUM", to be held in Bogota, Colombia, on March 16th. thru 20th. (immediately after the "XXI CONCILIUM OPHTHALMOLOGICUM UNIVERSALE" of Mexico).

Subjects:

- 1) Refractive Keratoplasty:
  - a - Myopia Correction.
  - b - Hyperopia and Aphakia Correction.
  - c - Astigmatism Correction.
- 2) Cryoextraction of the Lens.

The lectures will be completed with round table discussions, films and surgical demonstrations.

Information: Apartado Aéreo 20945 Bogotá (2) - Colombia

Tienen el gusto de comunicar a Ud., que el "PRIMUM FORUM OPHTHALMOLOGICUM", tendrá lugar en Bogotá, Colombia, del 16 al 20 de Marzo de 1970. (Inmediatamente después del XXI CONCILIUM OPHTHALMOLOGICUM UNIVERSALE de México).

Temas:

- 1) Queratoplastia Refractiva:
  - a - Corrección Miopía.
  - b - Corrección Hipermetropía y Afaquia.
  - c - Corrección Astigmatismo.
- 2) Crioextracción del Cristalino.

Los temas serán complementados con mesas redondas, proyección de películas y sesiones quirúrgicas televisadas.

Información: Apartado Aéreo 20945 Bogotá (2) - Colombia.

**Maxidex** (Isopto)  
PREPARADO OFTALMICO ESTERIL - DEXAMETASONA

MAYOR POTENCIA +  
MAYOR ABSORCION CORNEAL +  
CONTACTO PROLONGADO +  
DOSIFICACION ACELERADA =

UN GRAN AVANCE EN LA OFTALMOTERAPIA CON ESTEROIDES

**Maxidex**<sup>TM</sup>  
Isopto<sup>®</sup>

Corticoesteroide-Antibacteriano **Maxitrol**

**Maxitrol**<sup>®</sup>

dexametasona 0.1%  
neomicina (como sulfato) 3.5 mg/ml  
sulfato de polimixina B 6,000 unidades/ml

Proporciona las ventajas  
única  
(dexametasona) combinadas  
con la actividad  
antibacteriana de  
amplio espectro.

**Alcon**

Alcon Laboratories International Co.  
Fort Worth, Texas, E.U.A.

# **PRIMUM FORUM OPHTHALMOLOGICUM**

**To be held in Bogota, (Colombia)  
16-20 March 1970 — Following the XXI  
International Congress of Mexico**



**Subjects: I ) Refractive Keratoplasty;**

- a) Myopia Correction.**
- b) Hyperopia and Aphakia Correction.**
- c) Astigmatism Correction.**

**II) Cryoextraction of the Lens.**



**INFORMATION: Instituto Barraquer de América  
Apartado Aéreo 20945  
Bogotá (2), D. E. Colombia, S. A.**



# **INSTITUTO BARRAQUER**

**LAFORJA, 88**

**BARCELONA [6]**

**ESPAÑA**

## **QUINTO CURSO INTERNACIONAL DE OFTALMOLOGIA**

BARCELONA, 11 - 16 DE MAYO DE 1969

El programa comprenderá los siguientes temas:

**Microcirugía; Queratoplastia Refractiva; Desprendimiento de Retina; Colapso de la Cámara Anterior en Cirugía de la Córnea, de la Catarata y del Glaucoma.**

Están previstas asimismo varias SESIONES CINEMATOGRAFICAS (tema libre) y SESIONES QUIRURGICAS televisadas.

INFORMACION E INSCRIPCIONES EN LA SECRETARIA DEL INSTITUTO